

Honda Genuine Accessories

Applicable model
NC700S/SA/SD

GRIP HEATER ATTACHMENT INSTALLATION INSTRUCTIONS

Publications No.

Issue Date
January 2012

Honda Dealer:
Please give a copy of these instructions to your customer.

PARTS LIST

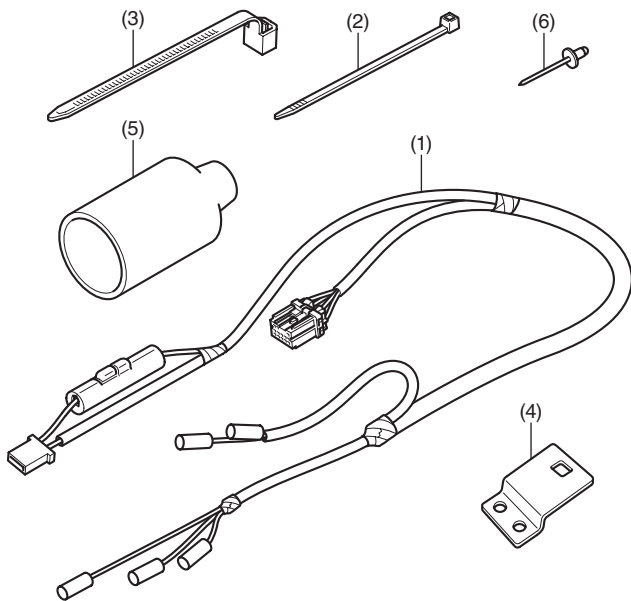

No.	Description	Qty
(1)	Grip heater harness	1
(2)	Wire tie (narrow)	6
(3)	Wire tie (wide)	4
(4)	Grip heater stay	1
(5)	Harness boot	1
(6)	Rivet	2

GRIP HEATER KIT

Sold separately (P/N 08T50-MGE-800)

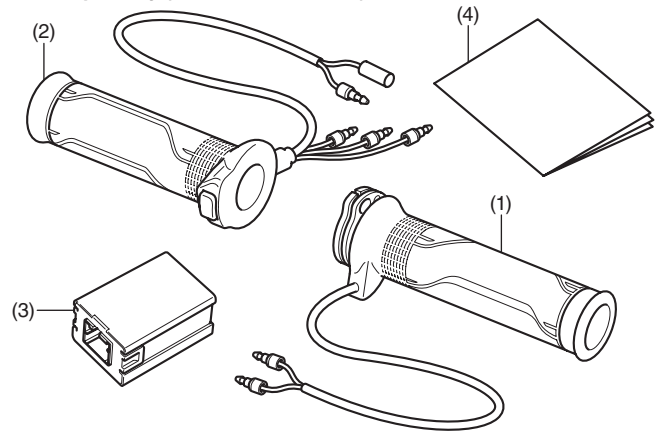

No.	Description	Qty
(1)	Right grip heater	1
(2)	Left grip heater	1
(3)	Controller	1
(4)	Owner's Manual	1

SUB HARNESS

Sold separately (P/N 08A71-MGS-D10)

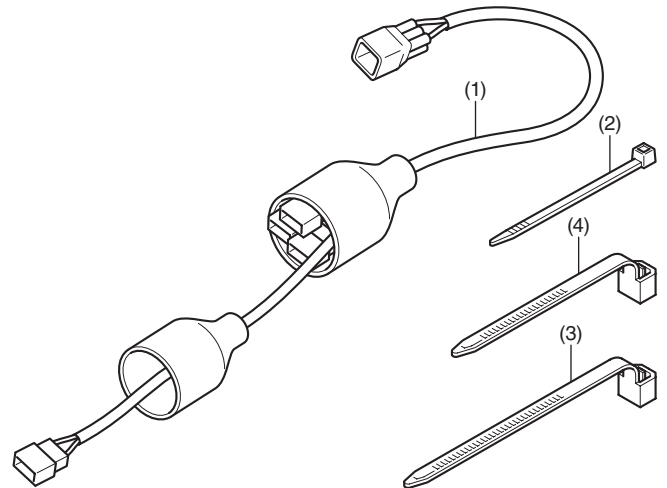

No.	Description	Qty
(1)	Sub harness	1
(2)	Wire tie (narrow) [Not used.]	1
(3)	Wire tie (long)	1
(4)	Wire tie (short) [Not used.]	2

RELAY SET

Sold separately (P/N 08A70-MGS-D30)

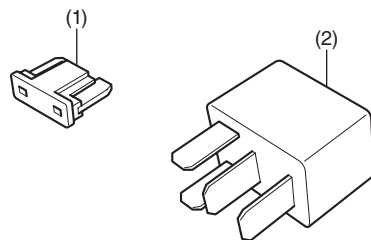

No.	Description	Qty
(1)	Fuse (7.5 A)	1
(2)	Relay	1

TOOLS AND SUPPLIES REQUIRED

Nippers
Electric drill
Drill bit (3.3 mm)
Awl
Riveter
Scissors
Scale
Marker
Electrical tape
Honda Bond A
Grease
Thread lock
Isopropyl alcohol
Shop towel

TORQUE INFORMATION

Refer to the Service Manual for the torque values of the removed parts.

USE AND CARE INFORMATION

- Use a 5A fuse for replacement of the fuse of this accessory harness. Do not use any other fuse for replacement.
- Use a 7.5A fuse for replacement of the fuse of the relay set. Do not use any other fuse for replacement.
- Check the accessory mounts frequently.
- Added accessories can affect a motorcycle's stability, performance and safe riding speed.

INSTALLATION INFORMATION

CAUTION:

- To prevent scalding, allow the engine, exhaust system, radiator, etc., to cool before installing the accessory.

NOTE:

- The following accessories are required to install the grip heater.
 - This accessory
 - Relay set (P/N 08A70-MGS-D30)
 - Sub harness (P/N 08A71-MGS-D10)
- The Relay set is not required for the motorcycle equipped with the Relay set.
- The Sub harness is not required for the motorcycle equipped with the Sub harness.
- Disconnect the throttle cables from the right grip as instructed in the motorcycle's Service Manual.
- For secure adhesion of the left grip heater to the handlebar, we urge you to use the recommended adhesive agent (Honda Bond A) and wait until it cures securely.
- Be sure to open and close the throttle to check for smooth operation after installation of the right grip heater.
- Take care not to damage the painted surfaces of the motorcycle.

- Reinstall the removed parts on the motorcycle and make sure that the wires and harnesses are not pinched.
- Disconnect the negative cable from the battery before installing this accessory.
- The memory of the clock will be erased when you disconnect the battery. Reset the clock after reconnecting the battery.
- Trim the excess ends off the wire ties after attaching them to the wire harnesses. Do not allow the cut part of the wire tie to interfere with another harness or brake pipe.
- After grip heater installation, check the lights (e.g. right / left turn signal lights and brake lights) for proper operation.
- When replacing the accessory that is required to install the Grip heater, follow the instructions described in this installation instructions.

PREPARING THE RELAY SET

- **These procedures are not required for the motorcycle equipped with the Relay set.**
1. Refer to the Service Manual for the motorcycle, remove the motorcycle parts, and disconnect the negative cable from the battery.

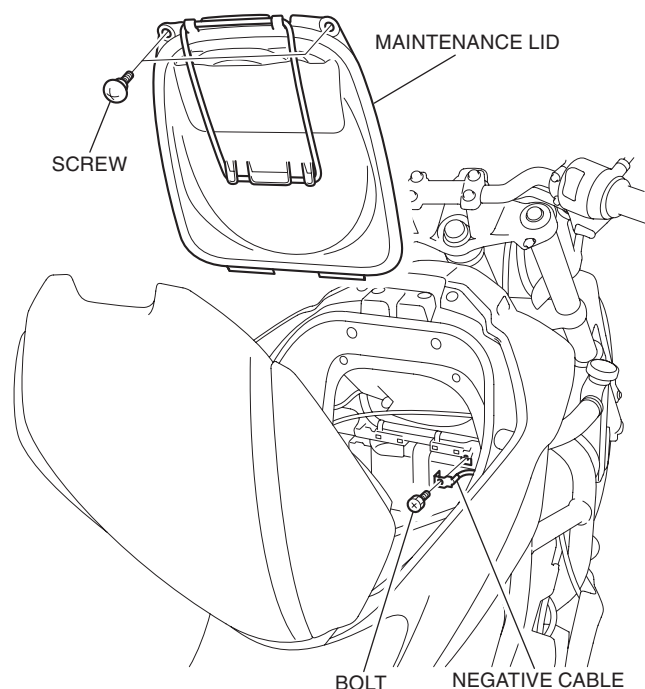

2. Remove the fuse box cover as shown.

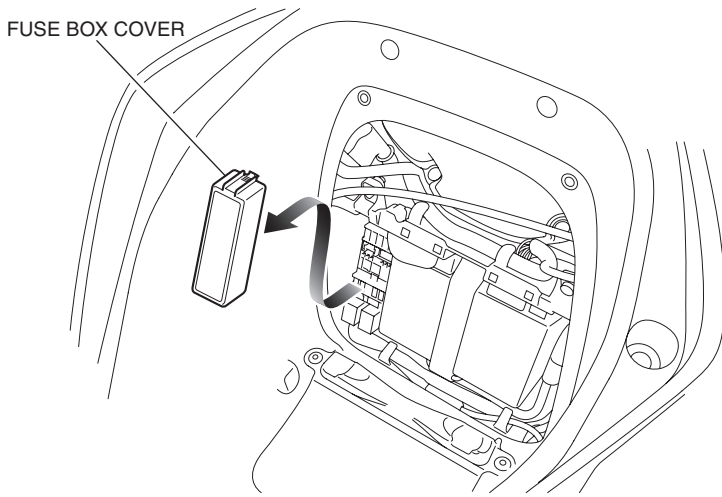

3. Install the relay and fuse in the position shown.

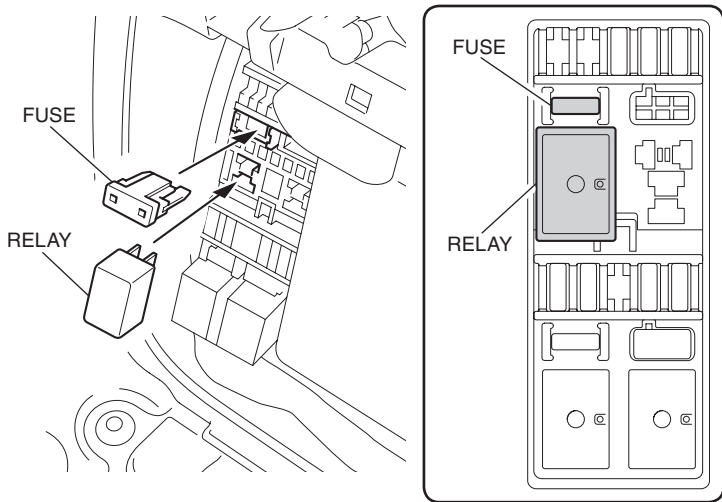

INSTALLATION

1. Refer to the Service Manual for the motorcycle, remove the motorcycle parts, and disconnect the negative cable from the battery.

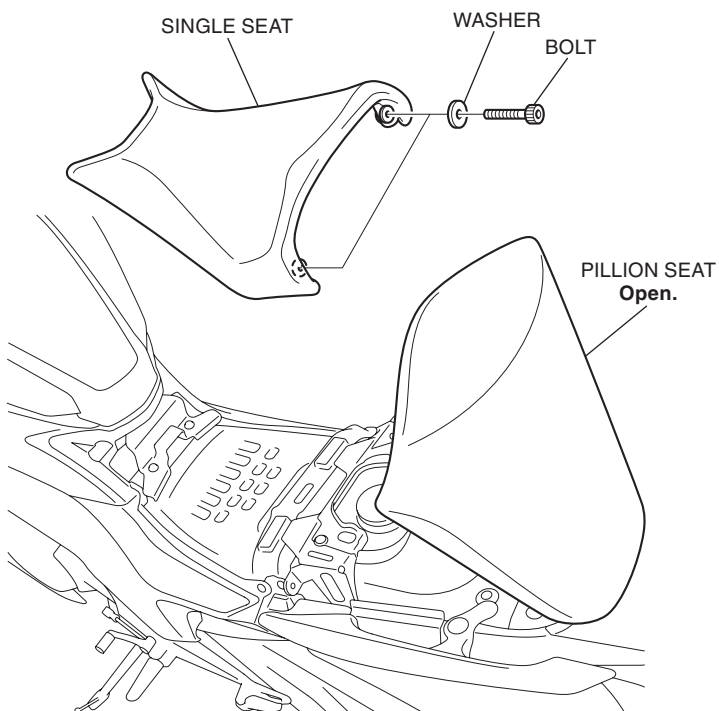

2. Refer to the Service Manual for the motorcycle, remove the motorcycle parts.

- Repeat on the right side.

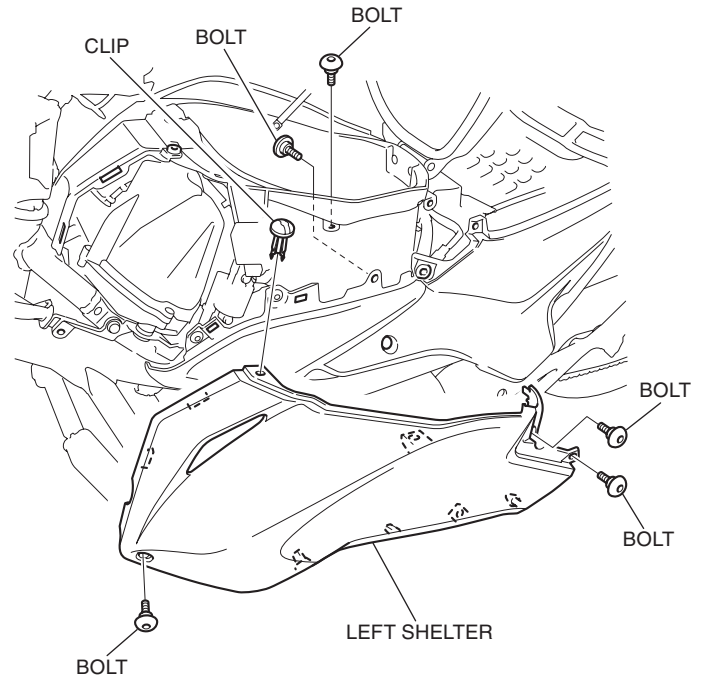

3. Remove the clip and open the front part of the left seat cowl slightly as shown.

- Repeat on the right side.

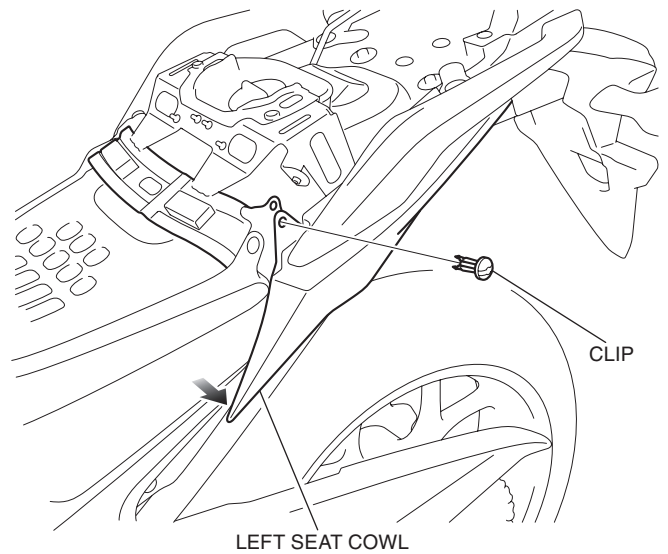

4. Refer to the Service Manual for the motorcycle, remove the motorcycle parts.

- Repeat on the right side.

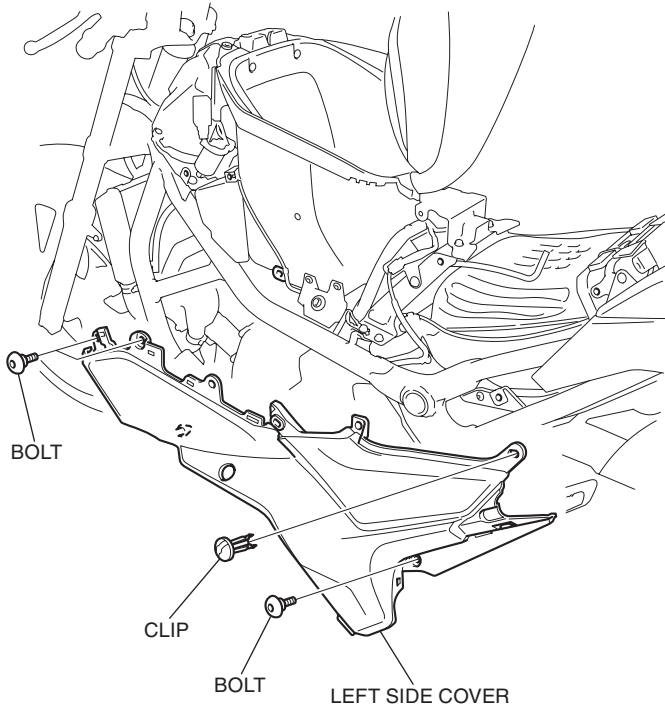

5. Refer to the Service Manual for the motorcycle, remove the motorcycle parts.

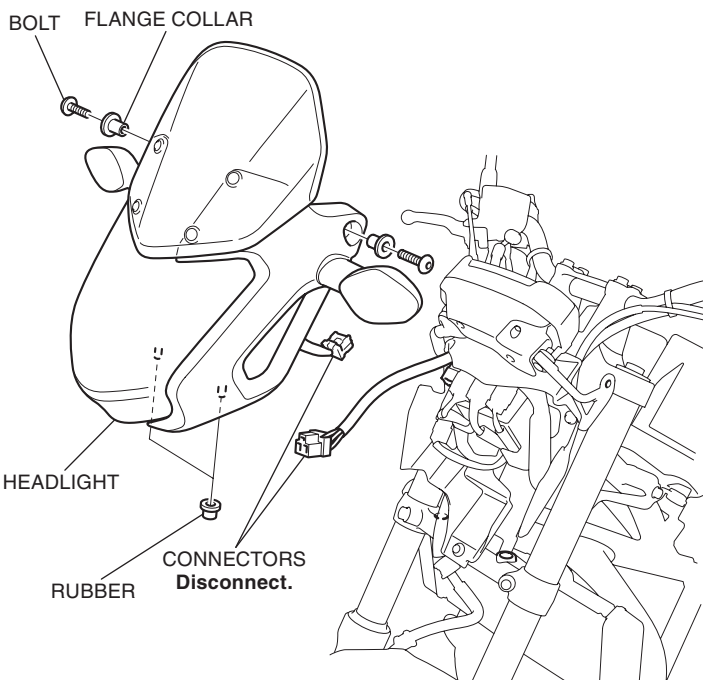

6. Cut and attach the templates to the luggage box and mark it using an awl as shown.

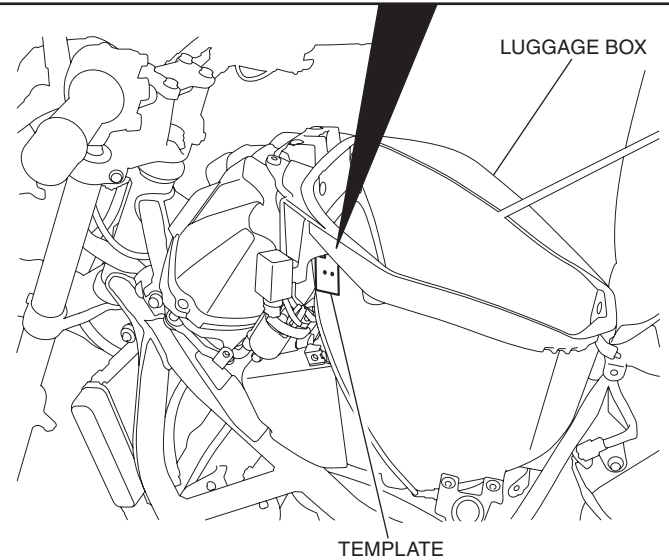
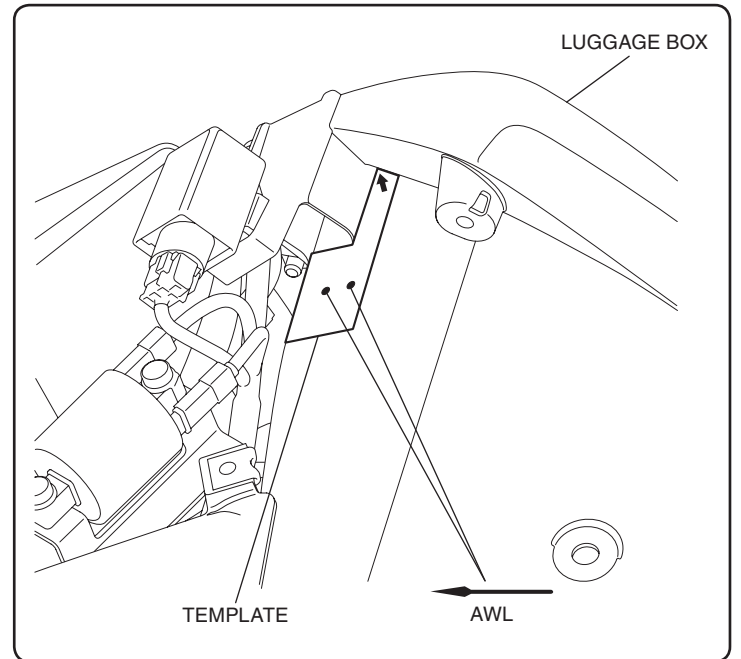

7. Remove the template. Drill at the marked point shown using an electric drill.

- Remove any burrs from the edge of the hole.

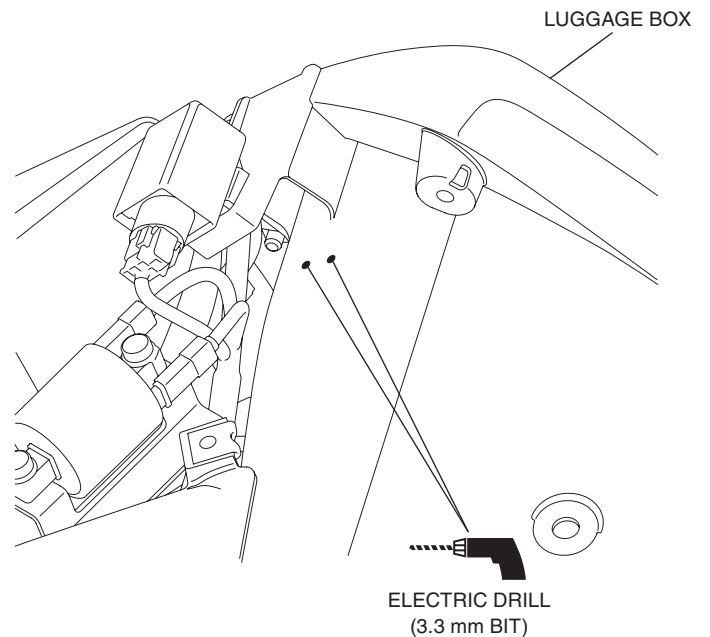

8. Install the grip heater stay as shown.

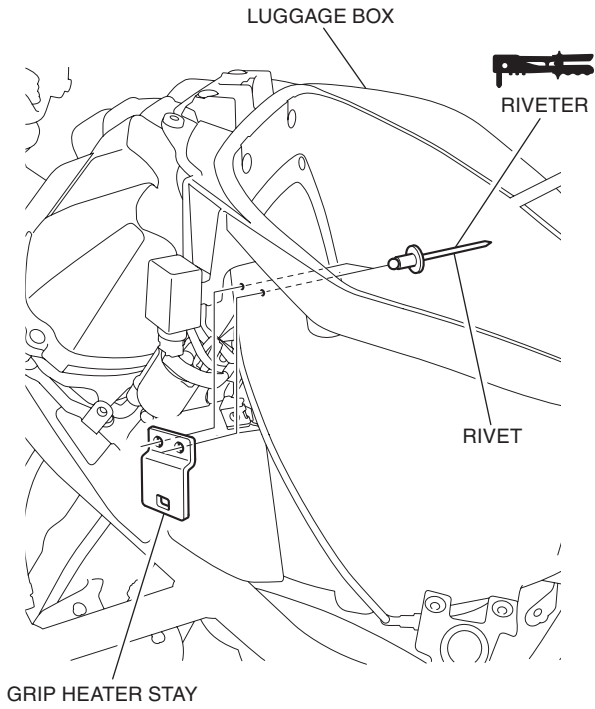

9. Pass the boot over the grip heater harness as shown.

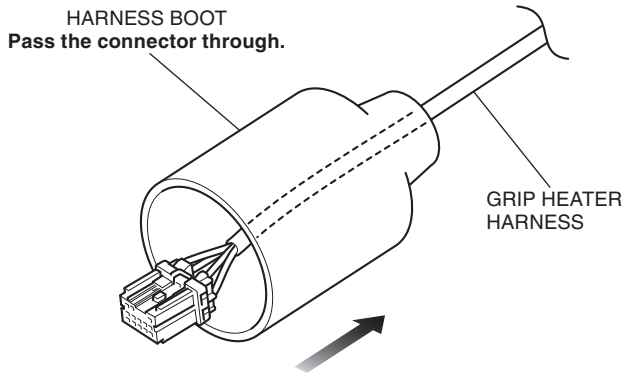

10. Connect the controller as shown.

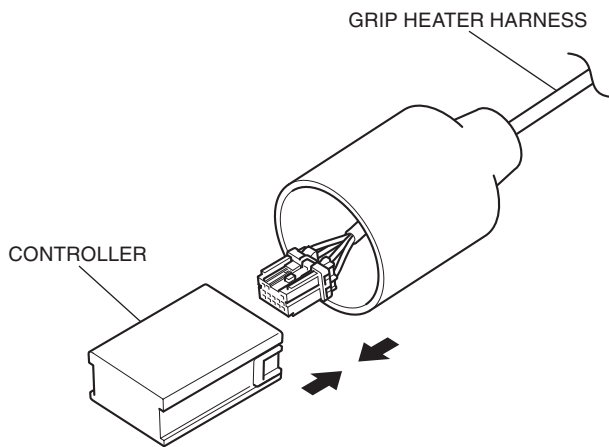

11. Install the controller as shown.

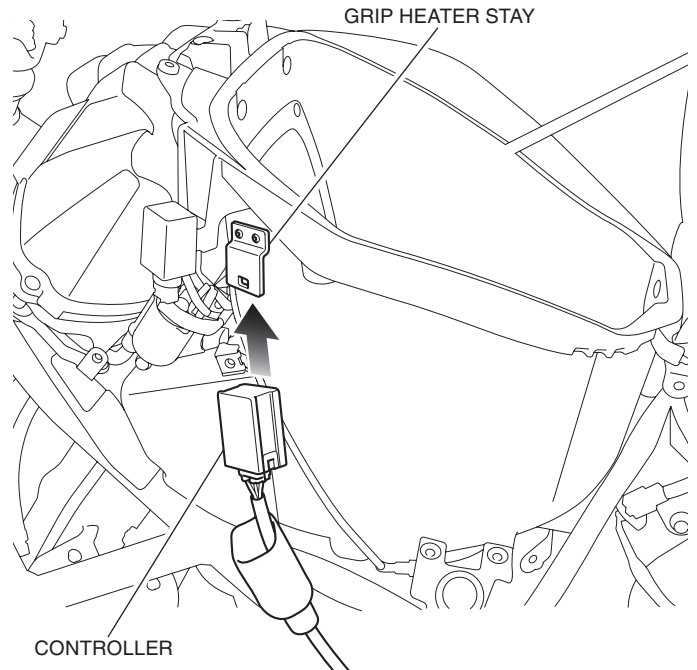

12. Fit the boot over the controller as shown.

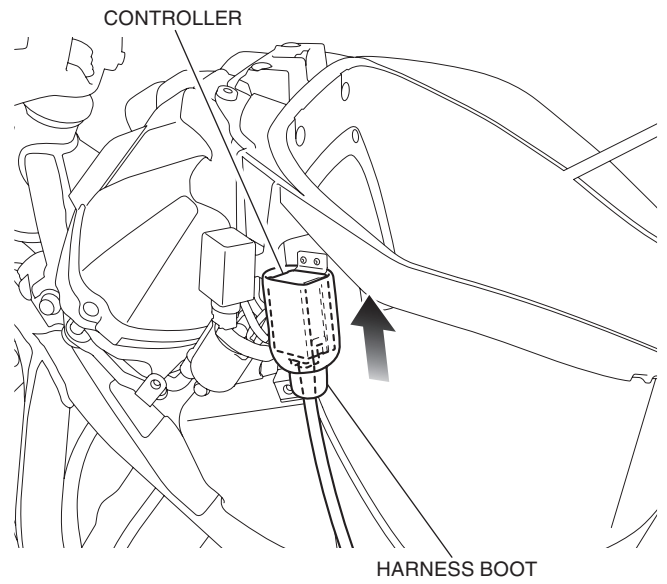

13. Release the motorcycle's 6-pin waterproof connector as shown.

- **This step is not required for the motorcycle equipped with the Sub harness.**

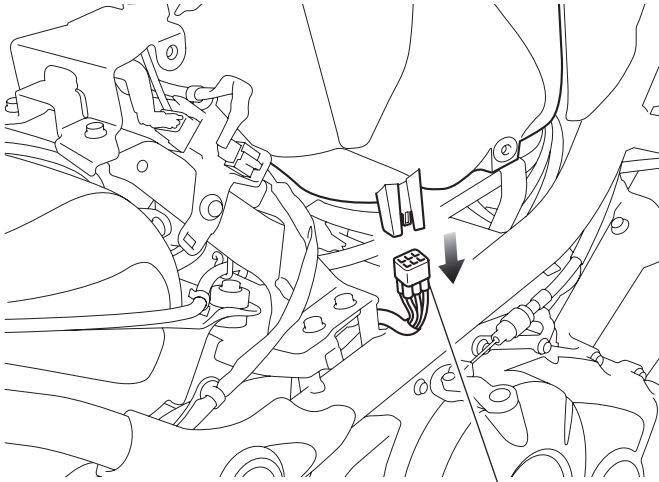

MOTORCYCLE'S 6-PIN WATERPROOF CONNECTOR

14. Connect the sub harness as shown.

- **This step is not required for the motorcycle equipped with the Sub harness.**

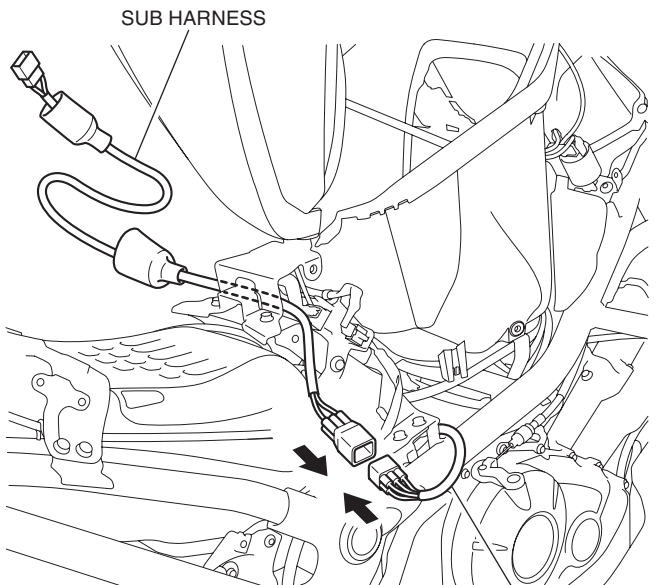

MOTORCYCLE'S HARNESS

15. Connect the grip heater harness as shown.

GRIP HEATER HARNESS

SUB HARNESS

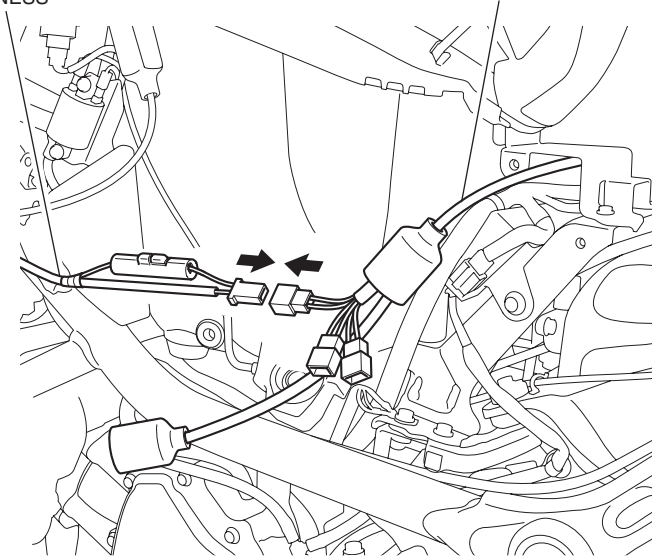

16. Cover the connectors with the harness boot as shown.

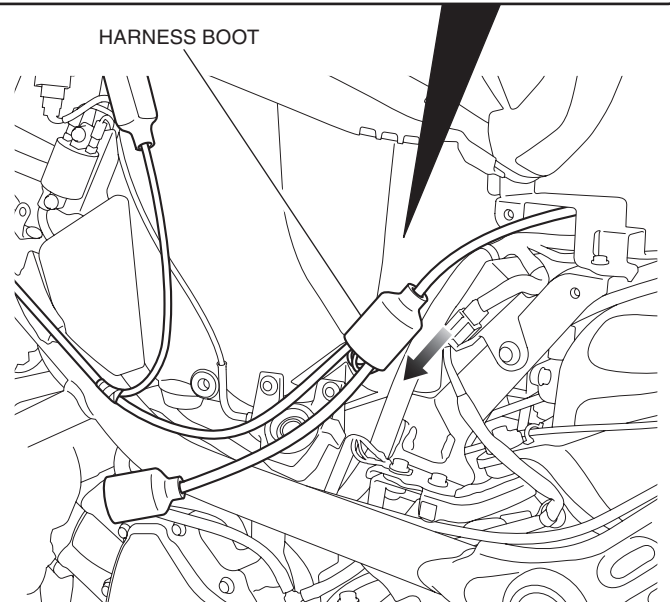
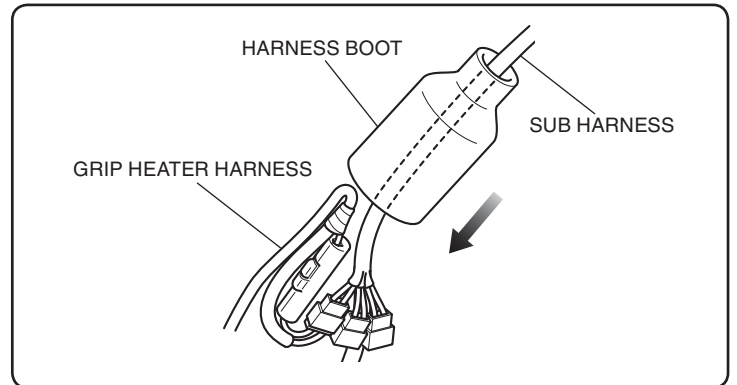

17. Pull the sub harness as shown.

- **This step is not required for the motorcycle equipped with the Sub harness.**

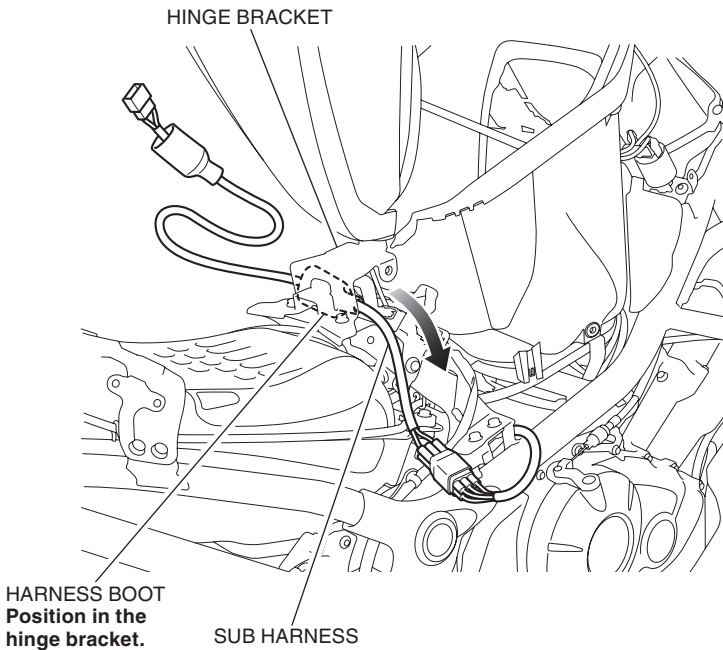

18. Secure the 6-pin waterproof connector with an electrical tape as shown.

- **This step is not required for the motorcycle equipped with the Sub harness.**

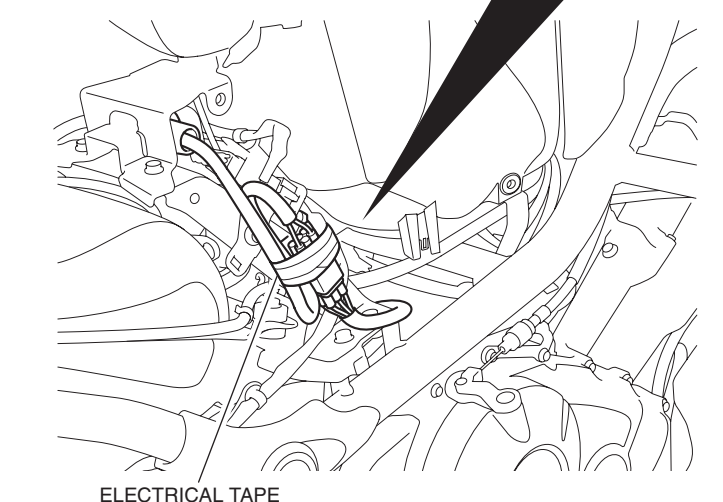
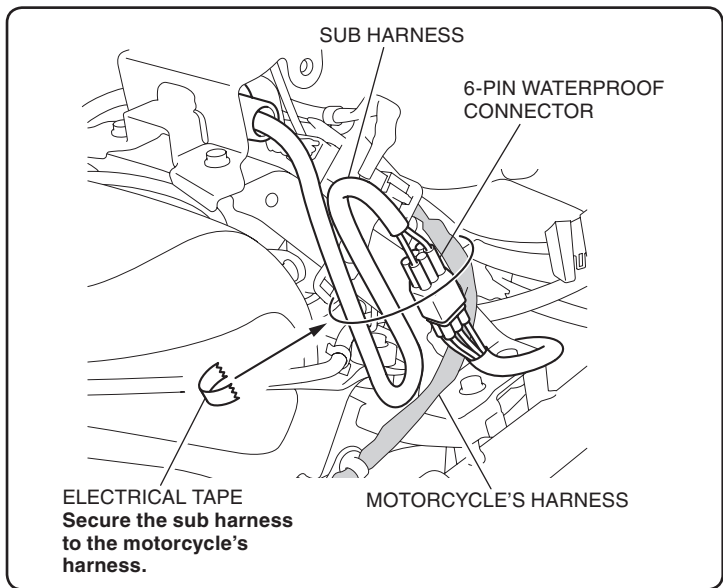

19. Secure each harness with the wire ties as shown.

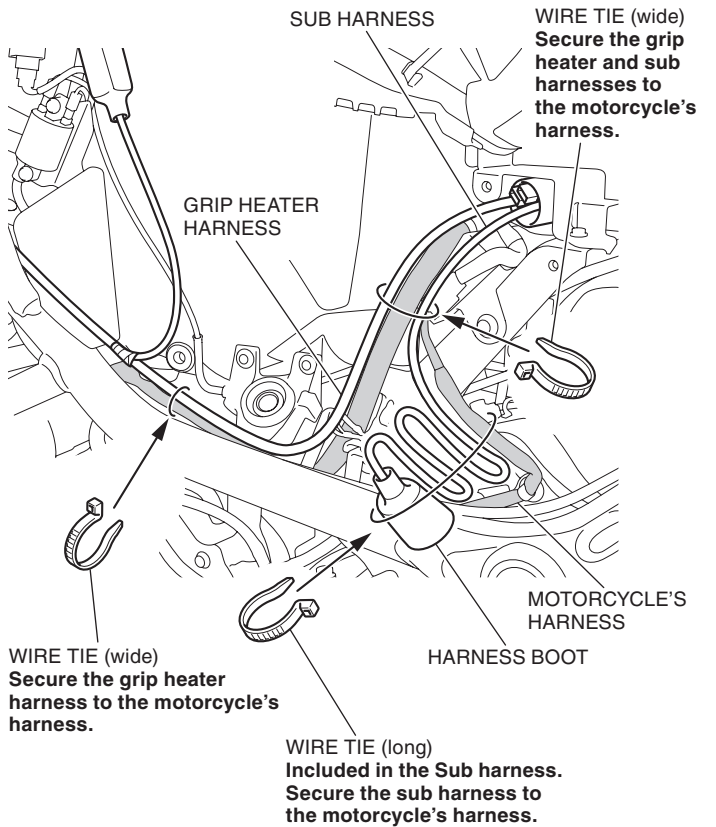

20. Route and secure the grip heater harness with the wire tie as shown.

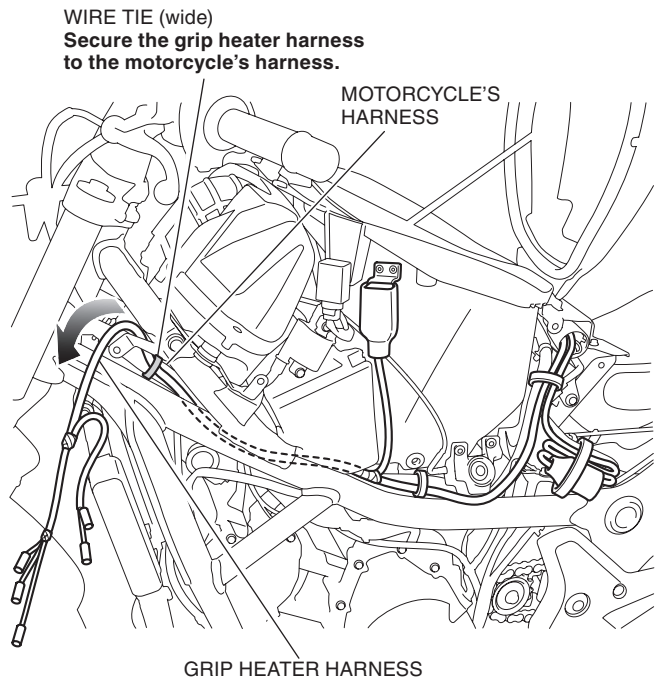

21. Remove the handlebar weight from the motorcycle as shown.

- Repeat on the right side.

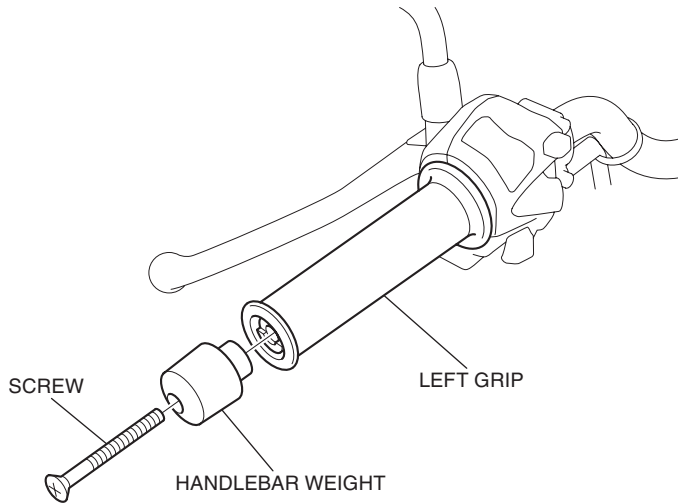

22. Remove the left grip as shown.

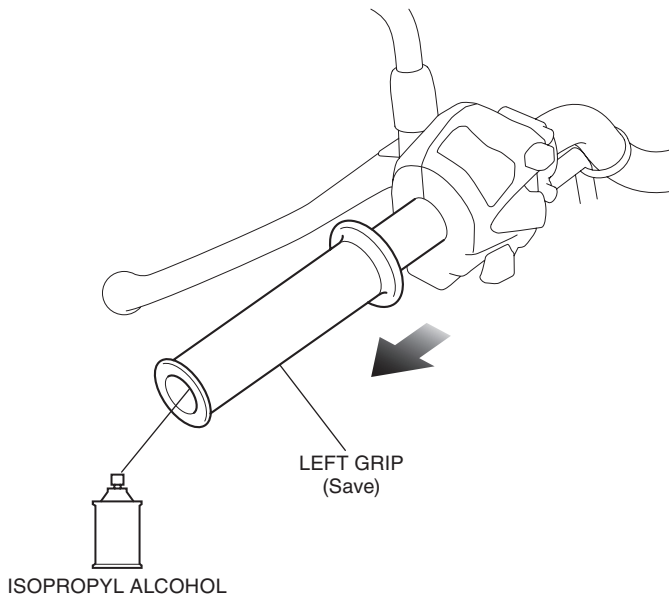

23. Using an isopropyl alcohol, remove all traces of adhesive from the left handlebar.

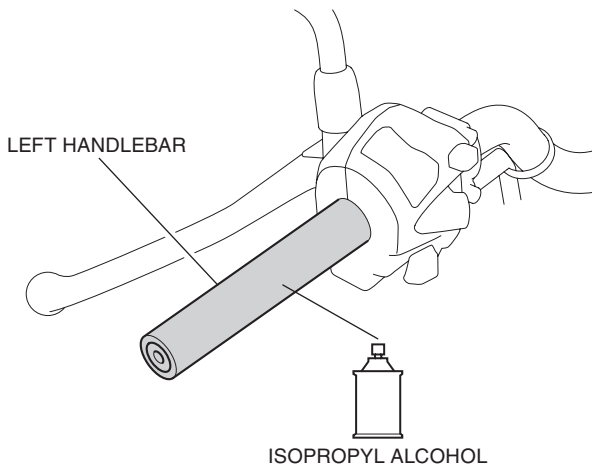

24. Liberally apply the Honda Bond A to the inside of the left grip heater from the kit as shown.

NOTE

Read the Instructions of the steps 24 through 27 carefully before installation and complete the operation quickly before the adhesive cures. Use an assistant to steady the motorcycle while installing the grip.

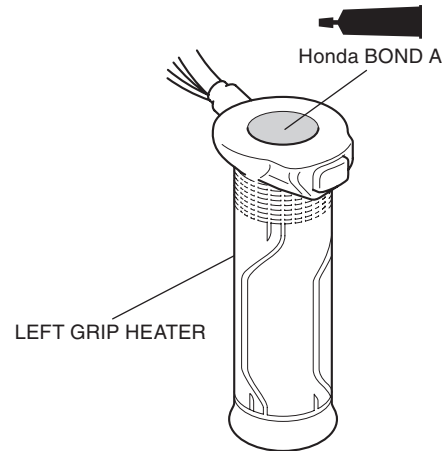

25. Apply Honda Bond A to the left handlebar as shown.

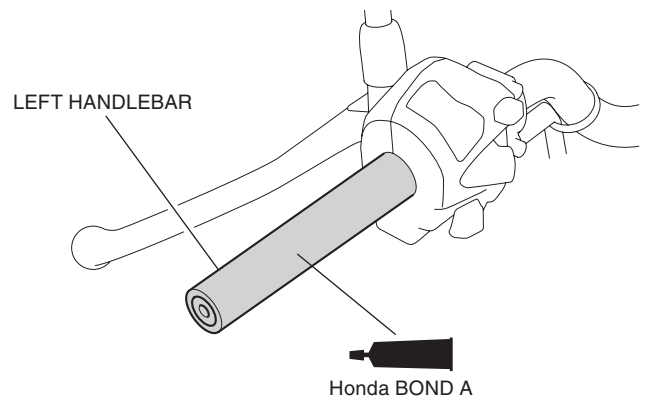

26. Spray isopropyl alcohol over the inside of the left grip heater and outside of the left handlebar.

- This is done to ease alignment between the grip heater and handlebar.

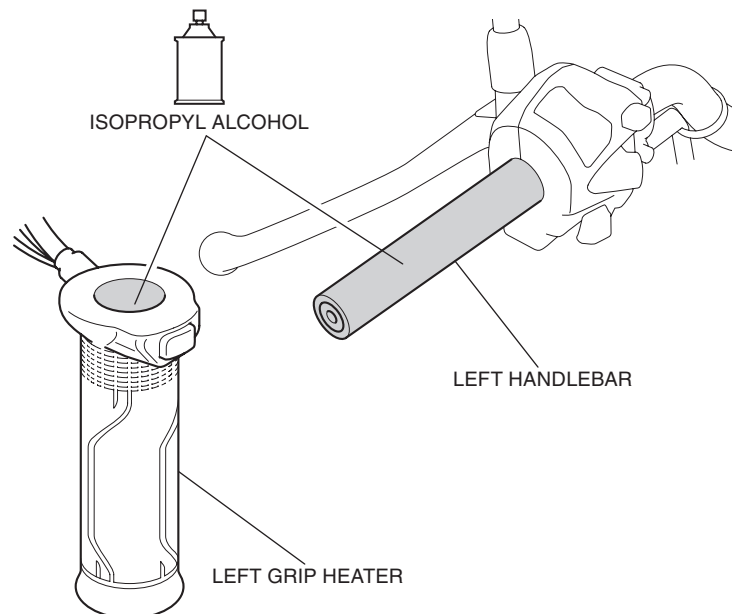

27. Slide the left grip heater onto the left handlebar as indicated.

- Wipe up excess adhesive at once.

NOTICE

- Do not tap on the grip end with a hammer and do not twist the grip with force to insert the left grip heater onto the handlebar, as it can damage the grip heater element.

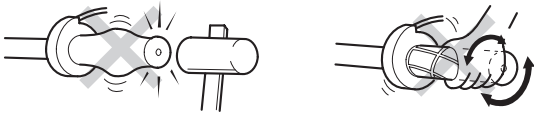

- Avoid putting pressure on the switch part when inserting the left grip heater. There is a possibility that the switch part will break. Also, install so that there is no gap with the left handlebar switch.



- If the grip gets stuck halfway during installation, apply isopropyl alcohol between the grip heater and handlebar. Do not try to remove the left grip heater using force or tools as the grip heater element can be damaged.

<NC700S/SA>

Insert until there is contact with the left handlebar switch, then align with the indicated position.

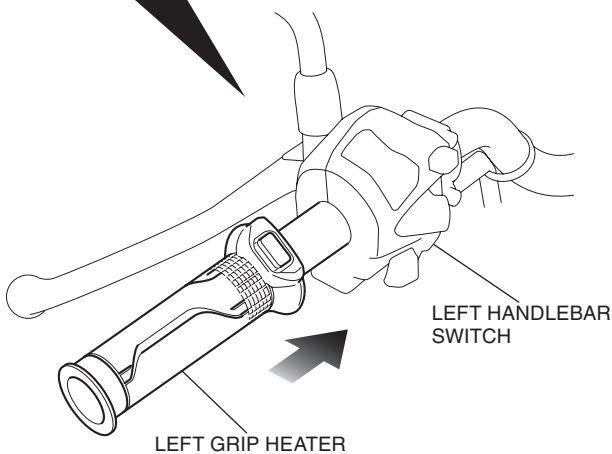
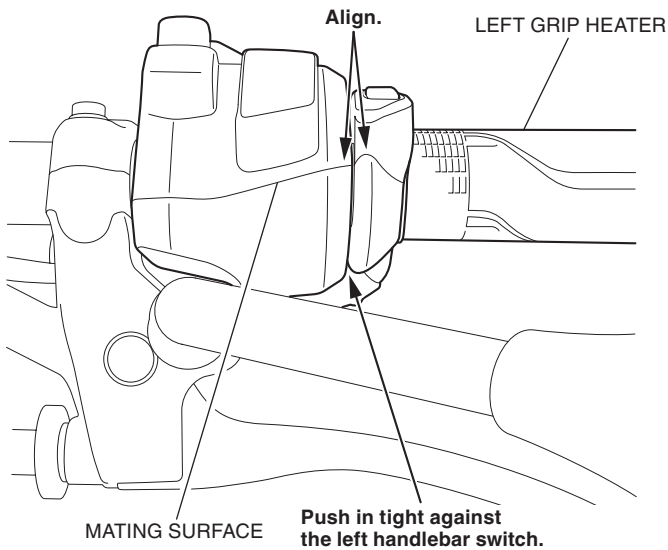

<NC700SD>

Insert until there is contact with the left handlebar switch, then align with the indicated position.

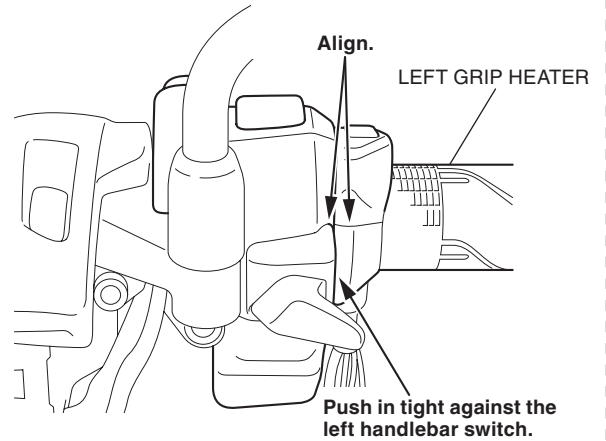

28. Reinstall the handlebar weight as shown.

- Before applying a thread lock, thoroughly clean the screw.

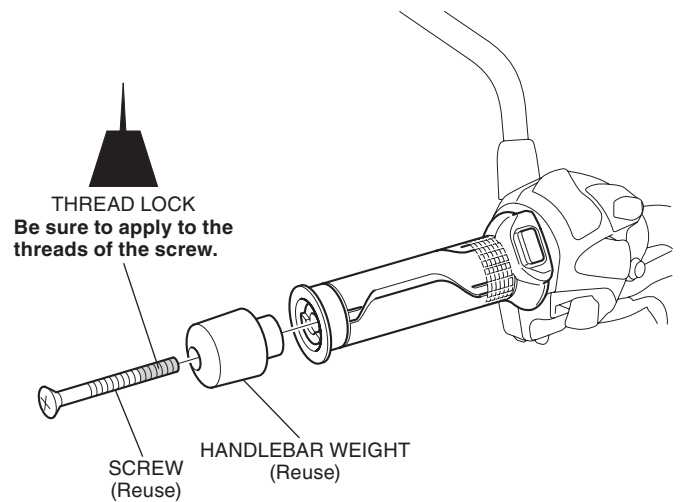

29. Route and connect the grip heater harness as shown.

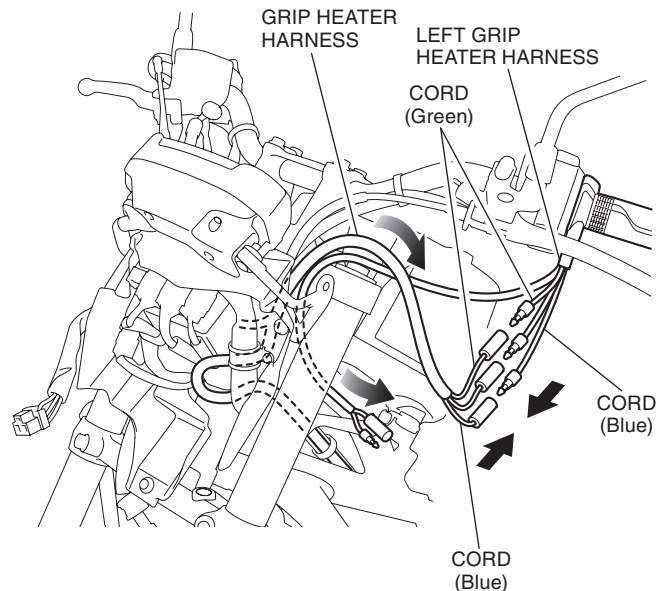

30. Wrap each harness with an electrical tape as shown.

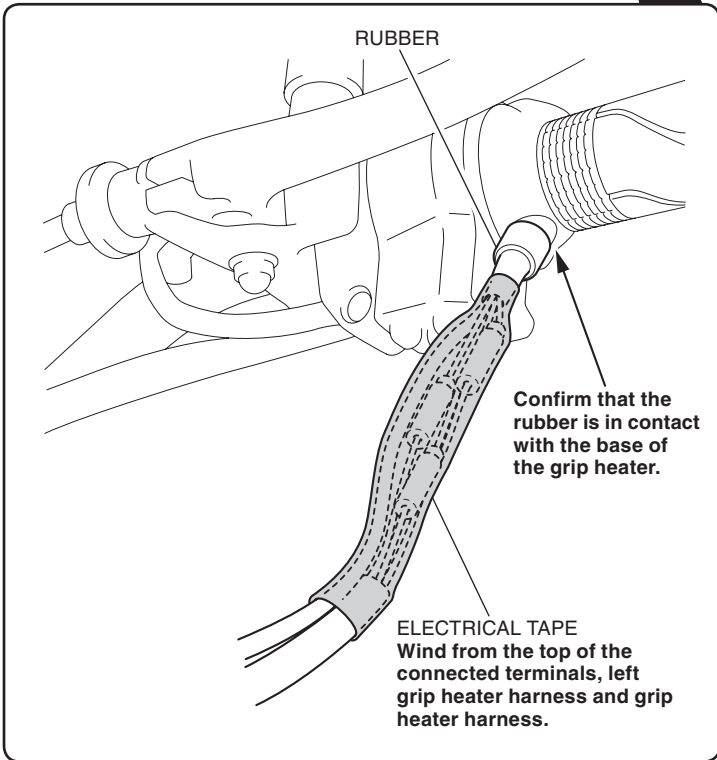
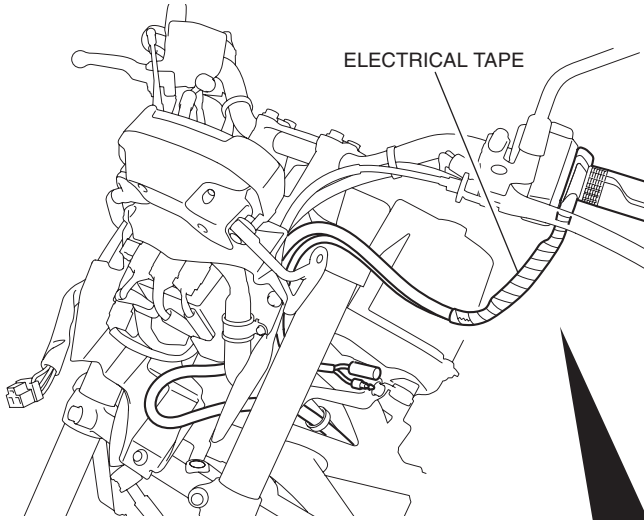

31. Secure each harness with the wire ties as shown.

MOTORCYCLE'S WIRE TIE (Reuse)
Secure the left grip heater and grip heater harnesses together with the motorcycle's harness.

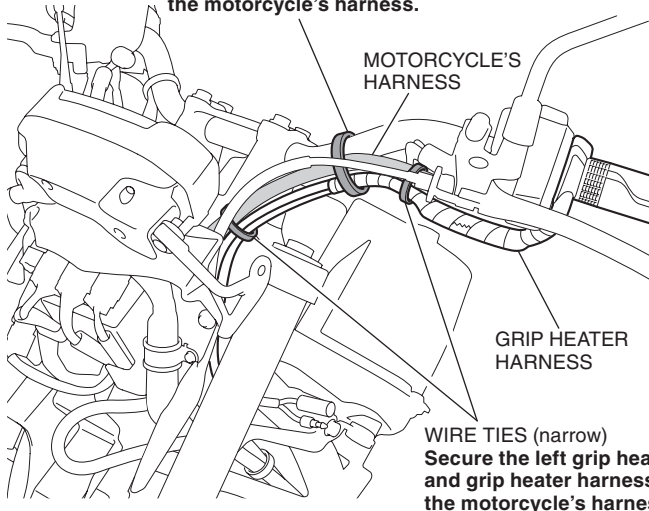

32. Secure the grip heater harness with the wire tie as shown.

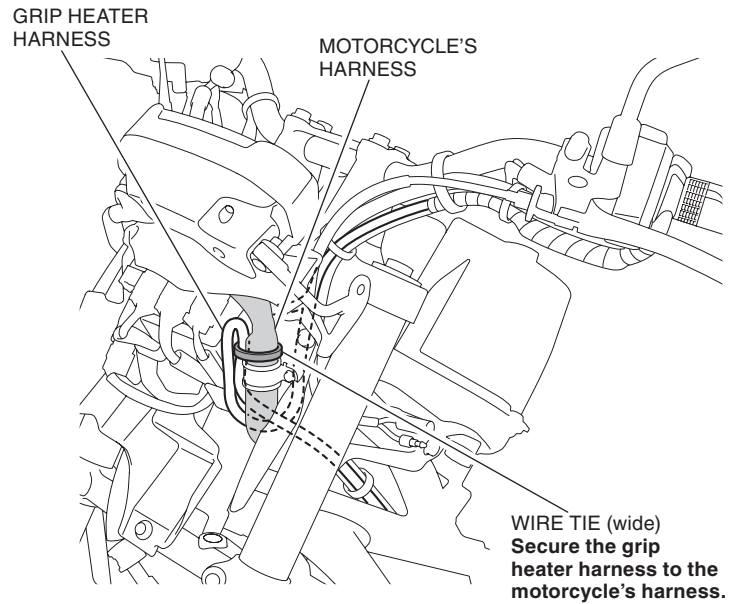

33. Route and secure each harness with the wire tie as shown.

WIRE TIE (narrow)
Secure the left grip heater and grip heater harnesses to the motorcycle's harness.

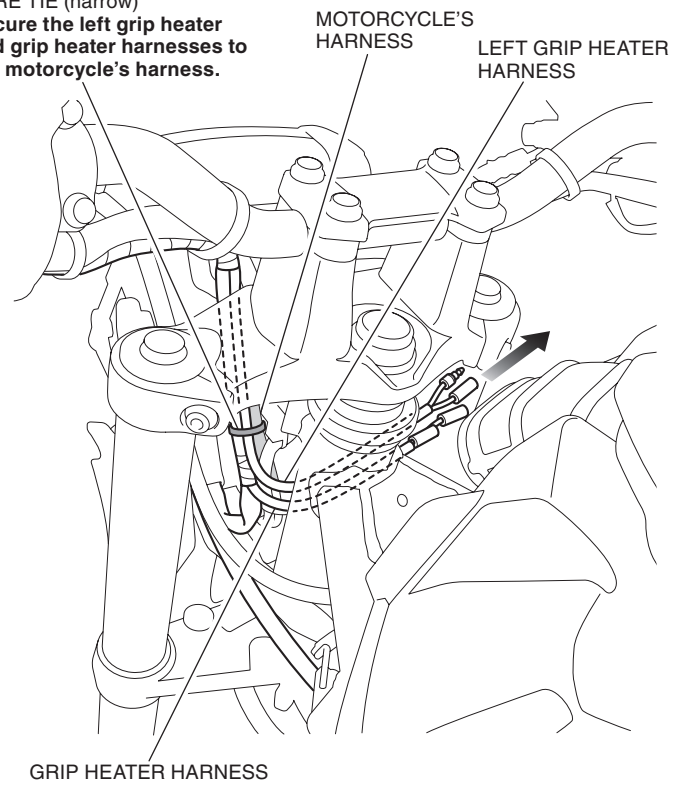

34. Loosen the bolts and slide the master cylinder as shown.

- **Be careful not to scratch the handlebar.**

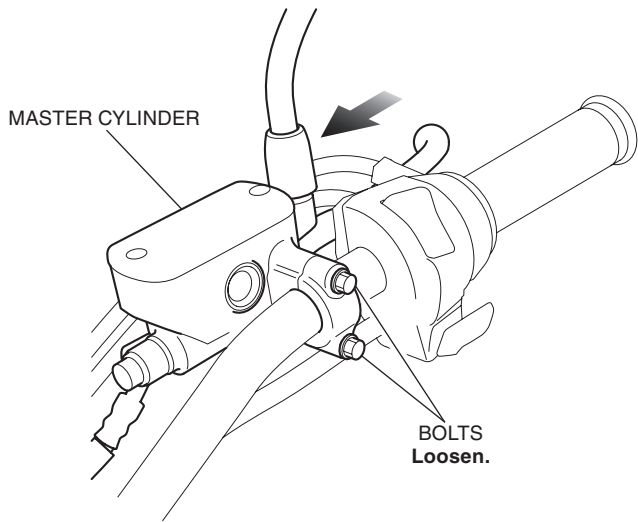

35. Remove the right handlebar switch as shown.

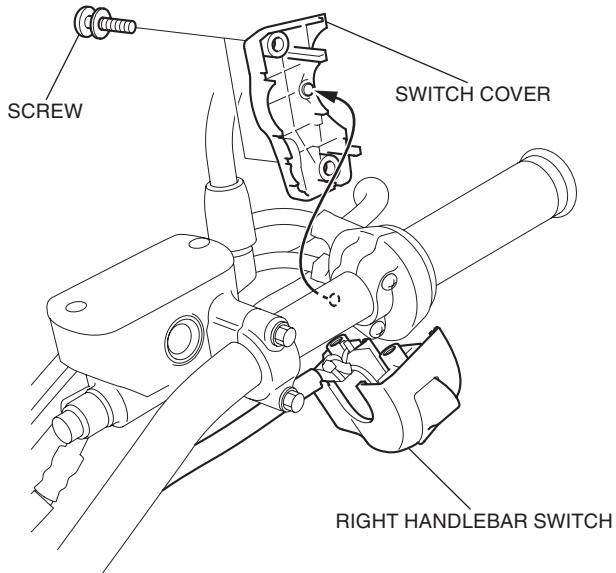

36. Remove the throttle housing cover as shown.

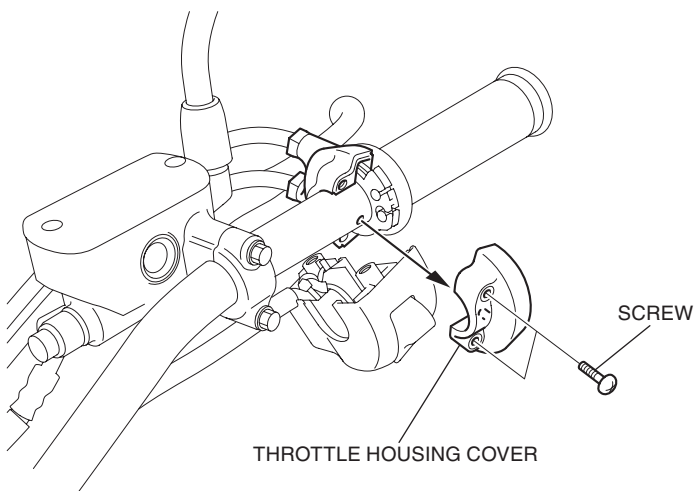

37. Remove the right grip as shown.

NOTE

Disconnect the throttle cable from the right grip as instructed in the motorcycle's Service Manual. Do not try to disconnect the cable with force using the pliers, etc. Refer to the motorcycle's Service Manual.

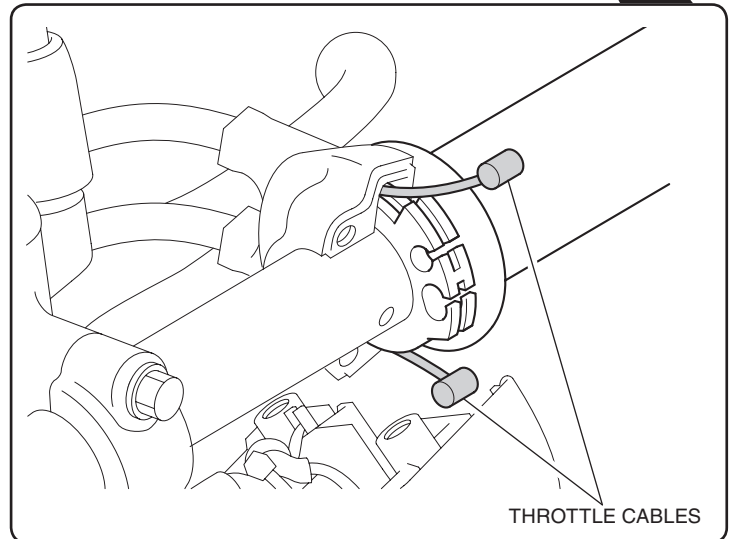
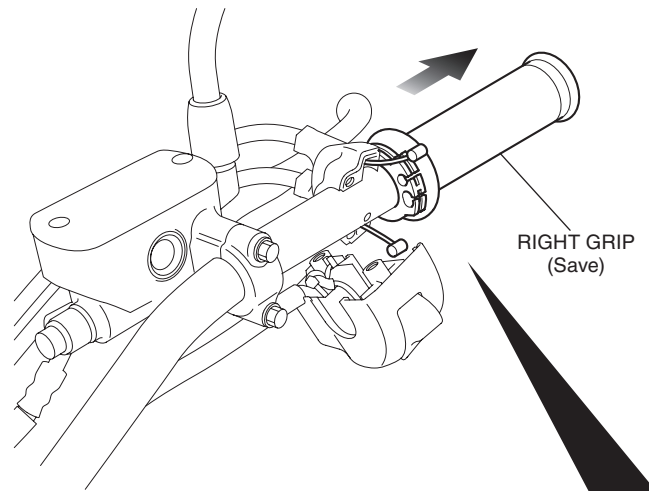

38. Mark the right grip heater harness in the position shown.

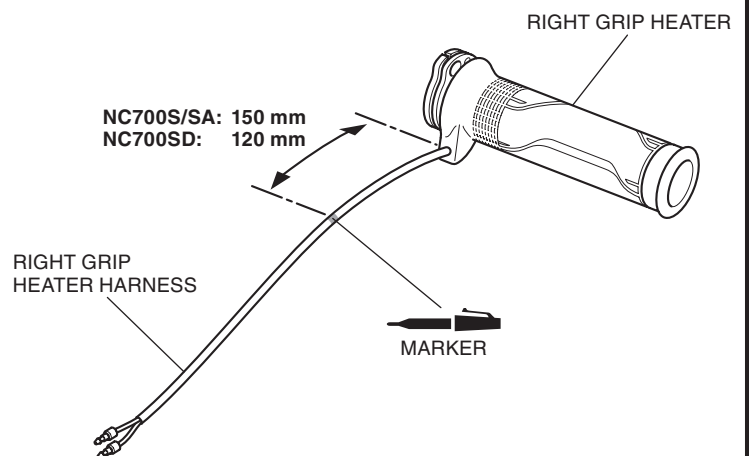

39. Apply grease to the  parts of the throttle cables and throttle pipe as shown.

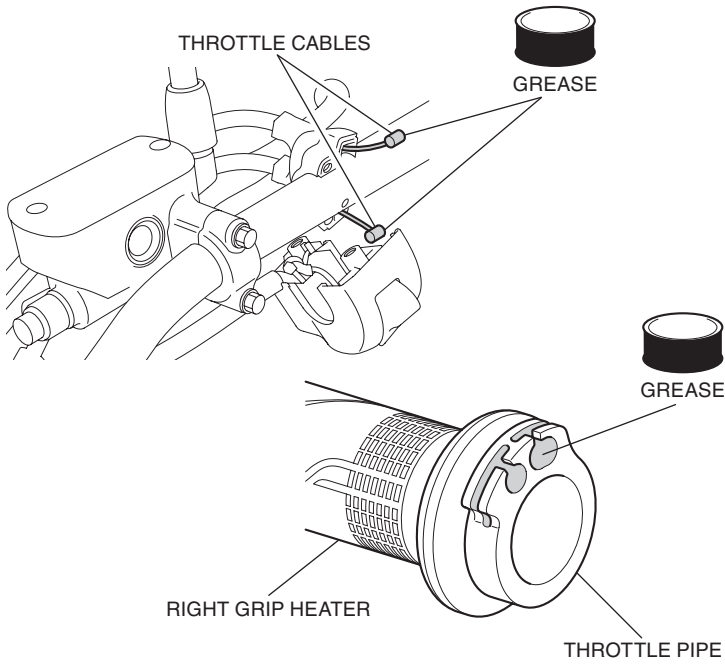

40. Install the right grip heater in the reverse order of the motorcycle's grip removal.

- **After installation, refer to the Service Manual and adjust the throttle freeplay.**

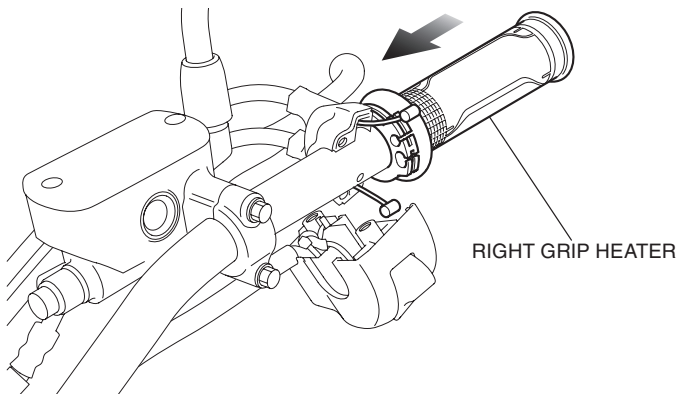

41. Reposition the master cylinder and tighten the bolts as shown.

- **Be careful not to scratch the handlebar.**

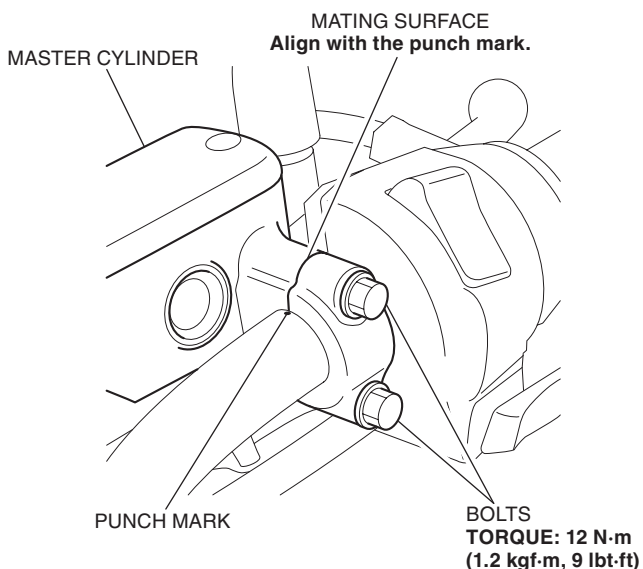

42. Reinstall the handlebar weight as shown.

- **Before applying a thread lock, thoroughly clean the screw.**

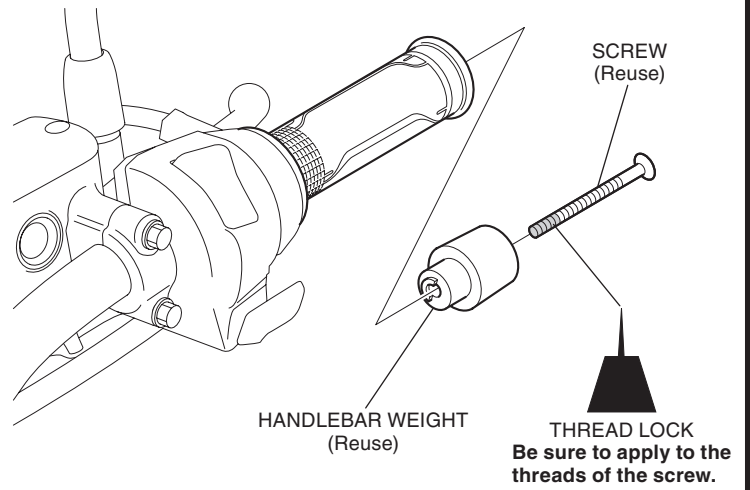

43. Twist the throttle grip as shown.

- **Check that the throttle opens and closes smoothly.**

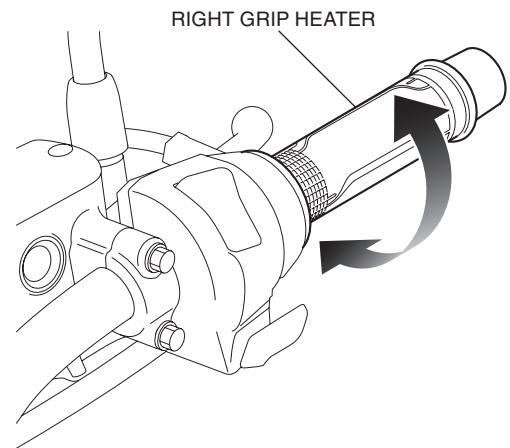

44. Route the right grip heater harness as shown.

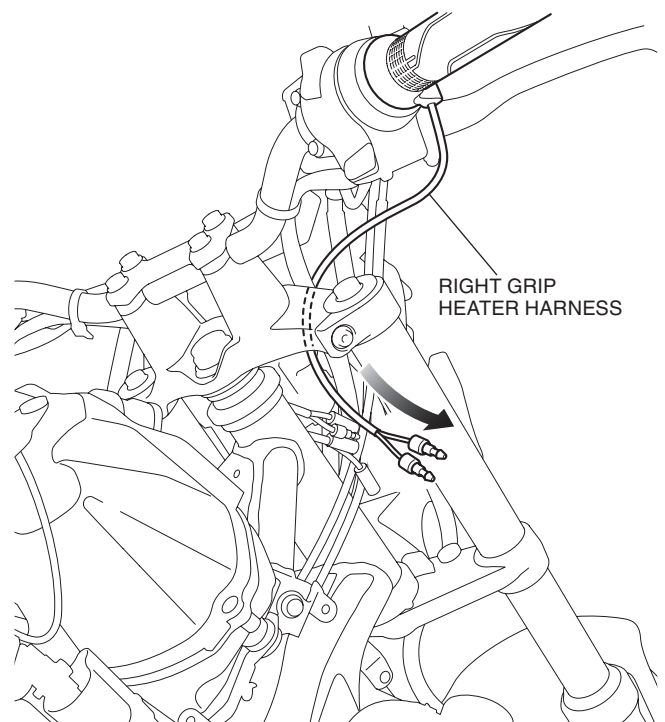

<NC700SD>

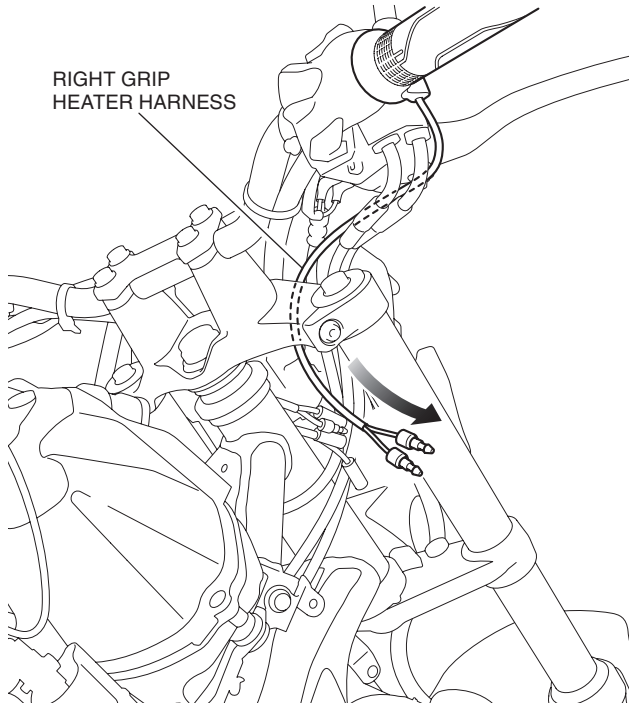

45. Secure the right grip heater harness as shown.
- **Open and close the throttle and confirm that there is no tightness of the grip heater harness.**

<NC700S/SA>

MOTORCYCLE'S WIRE TIE (Reuse)
Secure the right grip heater harness together with the motorcycle's harness.

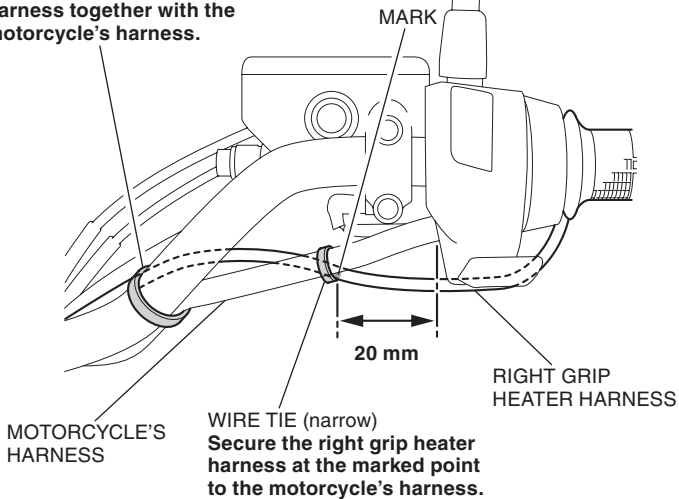

<NC700SD>

WIRE TIE E
Secure the right grip heater harness at the marked point to the throttle pipe.

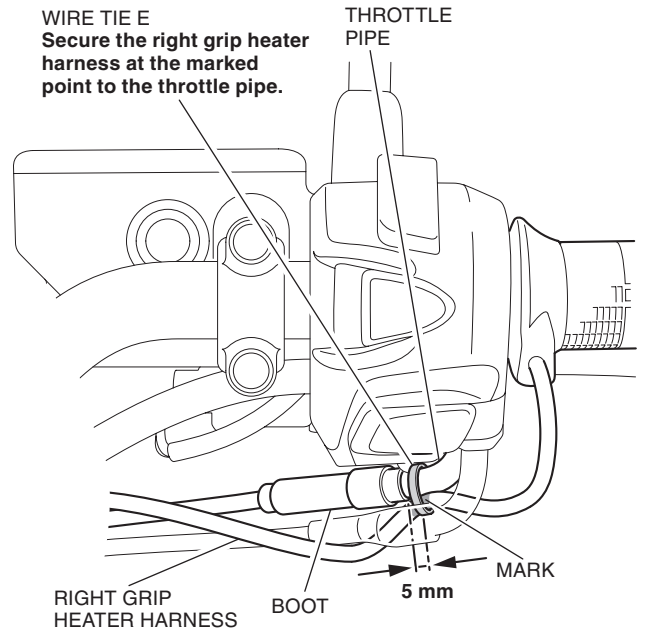

46. Connect each harness as shown.

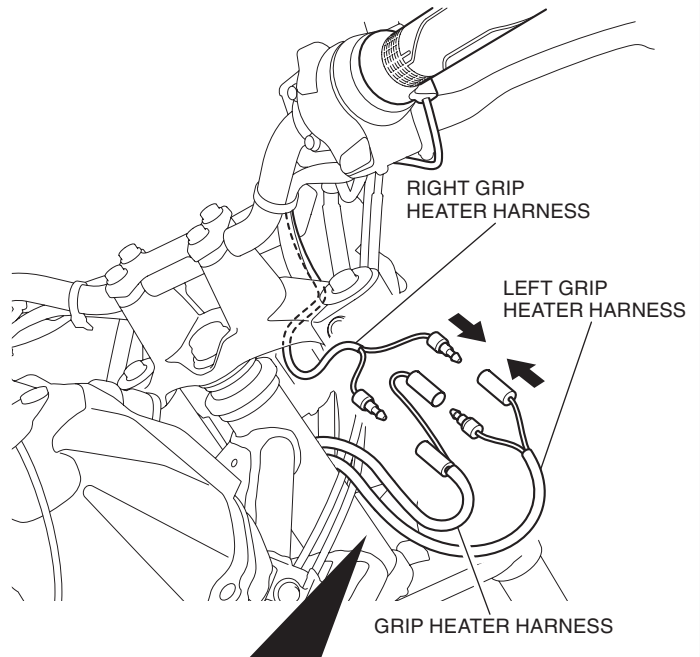

Wrap the electrical tape around the connection part.

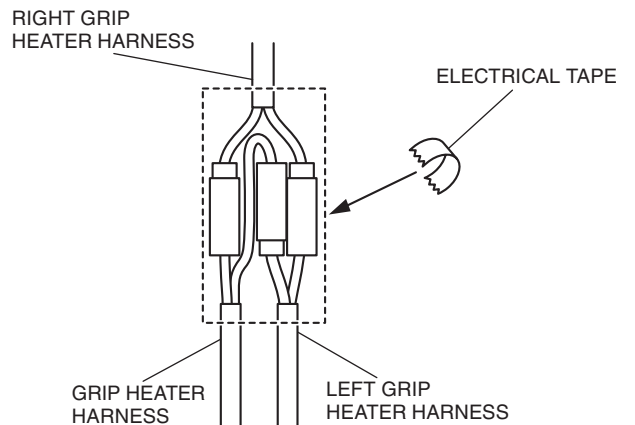

47. Secure the right grip heater harness with the wire ties as shown.

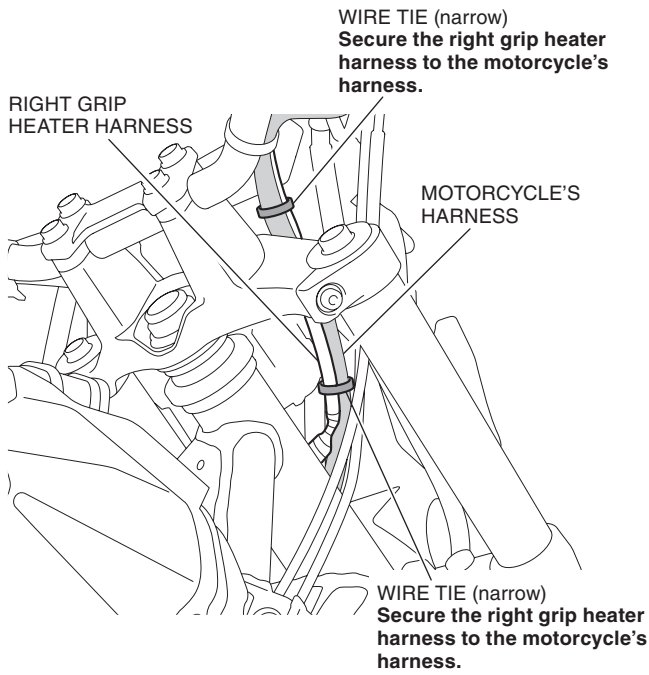

48. Check each harness for sufficient play.

- **Move the handlebar right and left and check that the harnesses are not pinched by the neighboring and that they are not pulled taut.**

49. Install the motorcycle's parts in the reverse order of removal.

- **Confirm that the harness is not caught or too tight.**

DEALER TROUBLESHOOTING

- Stop the engine and turn the ignition switch OFF when you check the parts and circuits other than those of the grip heaters.

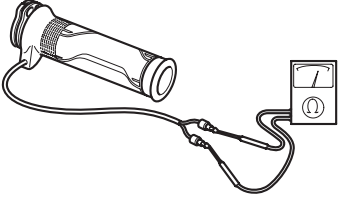
Symptom	Check
<p>Grip heater does not operate;</p> <ul style="list-style-type: none"> • Faulty grip heater • Faulty grip heater coil • Blown fuse • Open or short circuit in heater harness • Faulty heater switch 	<ol style="list-style-type: none"> 1. Check whether wires and cables (terminals and connectors) are connected securely. 2. Grip heater inspection Check for resistance between the terminals. <ul style="list-style-type: none"> ➔ Standard: <ul style="list-style-type: none"> Right : 2.2 ohms +/- 10% Left : 2.2 ohms +/- 10%  3. Heater harness inspection: Check for continuity. 4. If no abnormality is found after the above checks 1, 2, and 3, but the grip heater still does not operate properly, replace the heater switch with a new one. <ul style="list-style-type: none"> • It is hard to check the switch in ordinary inspection method (for continuity etc.) because it contains an IC circuit.

<TEMPLATE>

Cut off along the dotted line.

