



INSTALLATION INSTRUCTIONS

Accessory
TALL SCREEN
P/N 08R71-MKC-ED1

Application
GL1800/B/DA

Publication No.
MII
Issue Date
September 2017

Honda Dealer: Please give a copy of these instructions to your customer.

PARTS LIST

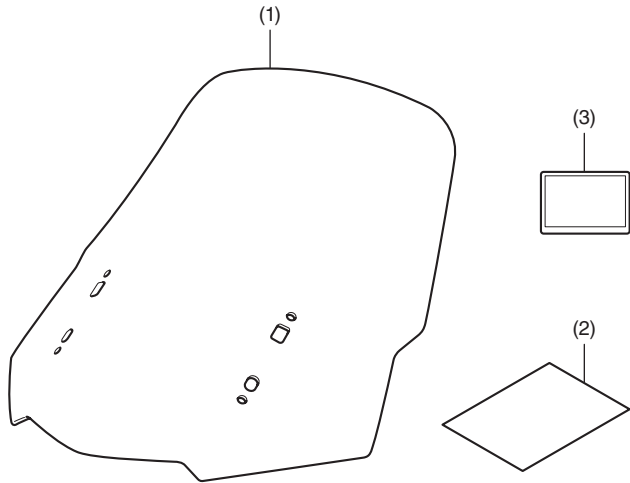

No.	Description	Qty
(1)	Tall wind screen	1
(2)	URL paper	1
(3)	Label	1

SUPPLIES REQUIRED

Scale

Synthetic detergent solution

(Water : Synthetic detergent / 100 : 1)

Shop towel

TORQUE CHART

Refer to the Service Manual for the torque values of the removed parts.

INSTALLATION

NOTE:

- Heat the bonding surfaces with a hair dryer if the ambient air temperature is below 70°F (21°C).
- The adhesive reaches full strength in 72 hours. Wait at least 24 hours before riding your motorcycle.

- Slide up the wind screen as shown.
 - **The wind screen position is fixed when turning the SCREEN UP/DOWN switch UP while turning the ignition switch OFF.**

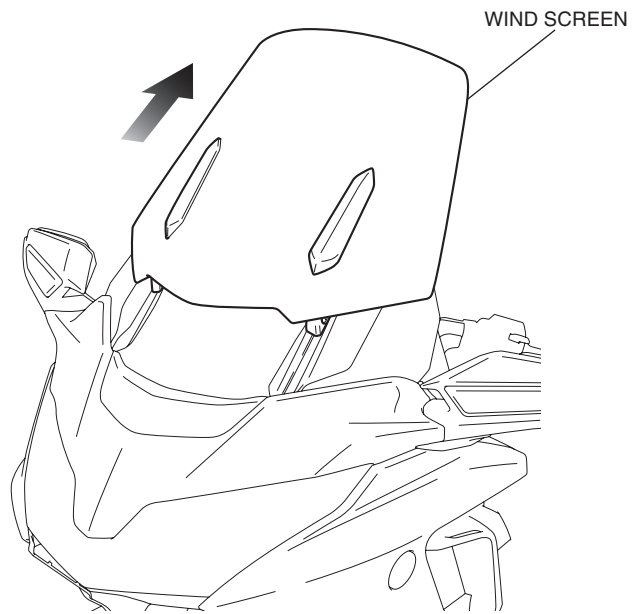

- Remove the right and left wind screen cover as shown.

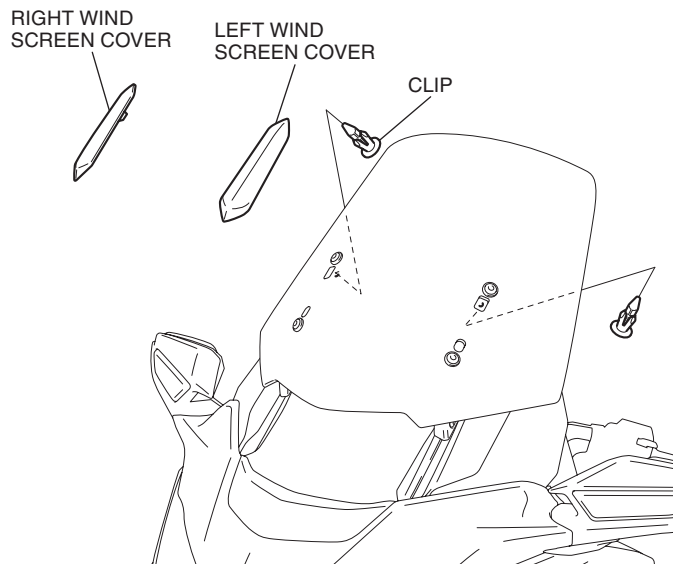

3. Remove the wind screen as shown.

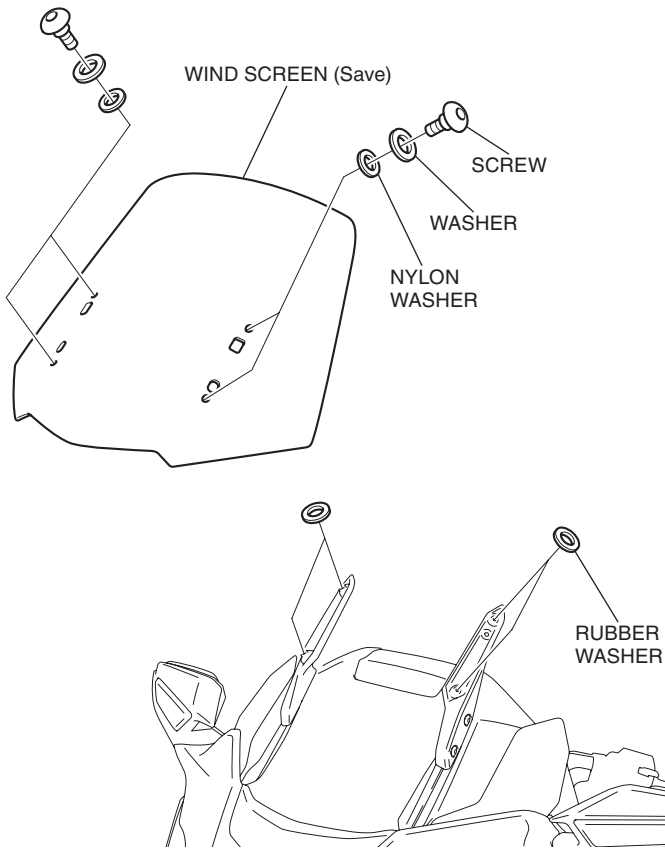

4. Install the rubber washers as shown.

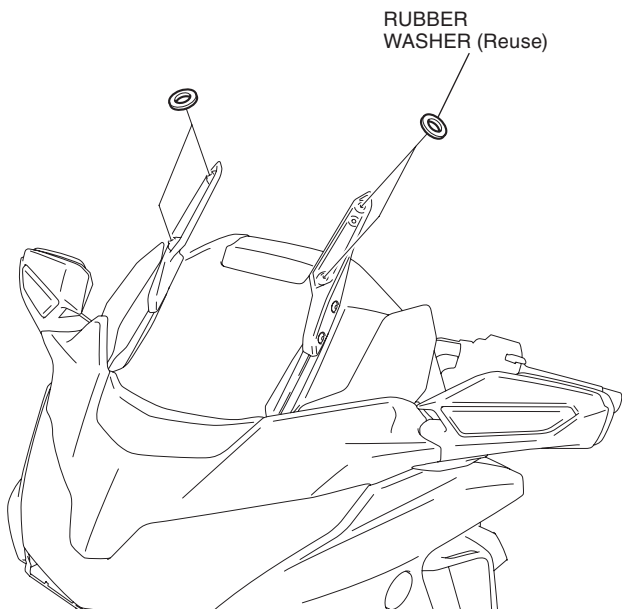

5. Install the tall wind screen as shown.

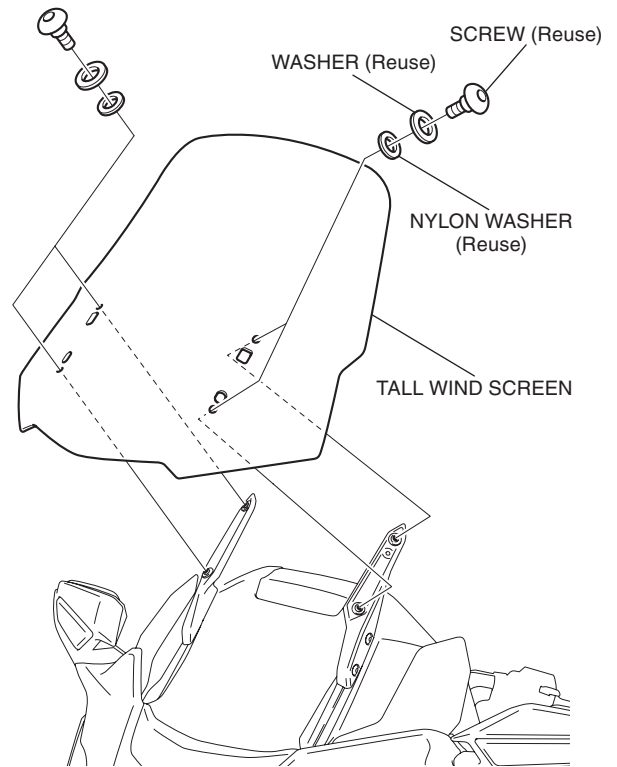

6. Install the motorcycle's parts in the reverse order of removal.

7. Attach the label in the position shown.

