



INSTALLATION INSTRUCTIONS

Accessory
HIGH WIND SCREEN
P/N 08R70-MKP-D00

Application
CBR500RA

Publication No.
MII
 Issue Date
October 2018

Honda Dealer: Please give a copy of these instructions to your customer.

PARTS LIST

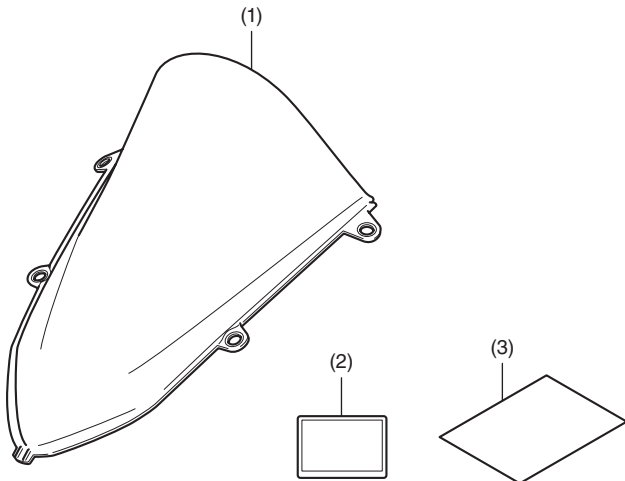

No.	Description	Qty
(1)	High wind screen	1
(2)	Label	1
(3)	URL paper	1

SUPPLIES REQUIRED

- Scale
- Synthetic detergent solution
(Water : Synthetic detergent / 100 : 1)
- Shop towel

TORQUE CHART

Refer to the Service Manual for the torque values of the removed parts.

INSTALLATION

- Heat the bonding surfaces with a hair dryer if the ambient air temperature is below 70°F (21°C).
- The adhesive reaches full strength in 72 hours. Wait at least 24 hours before riding your motorcycle.

1. Remove the parts as shown.

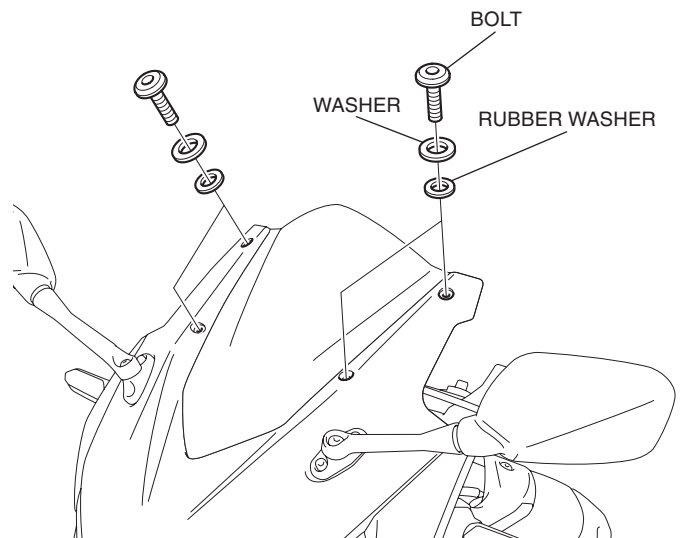

2. Remove the wind screen as shown.

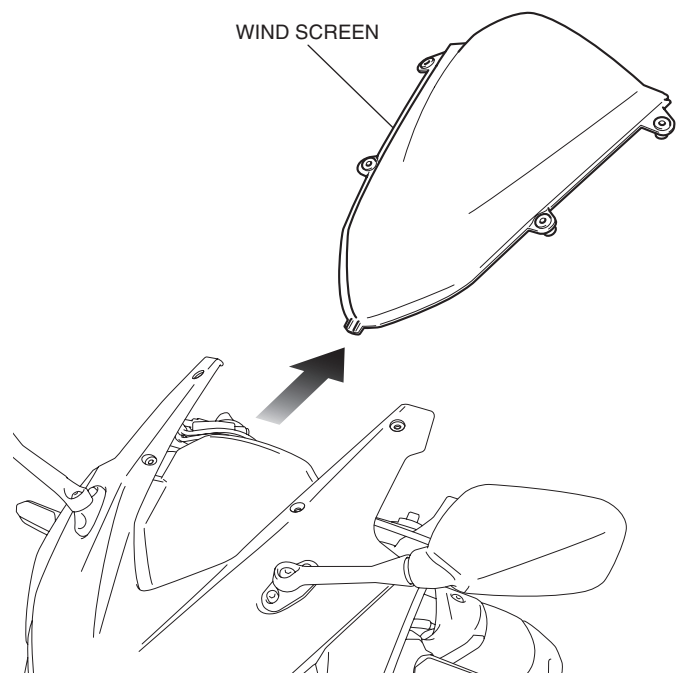

3. Remove the well nuts as shown.

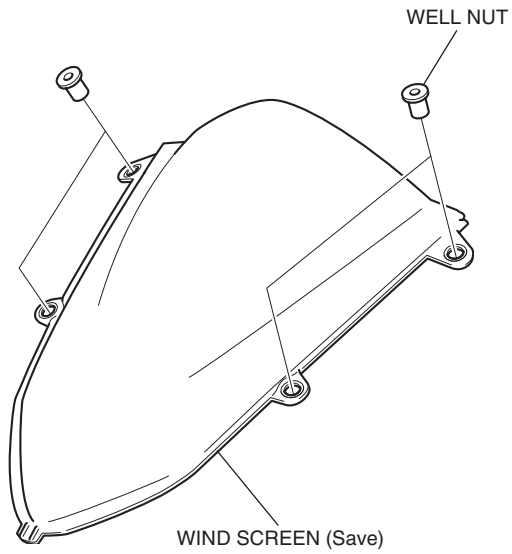

4. Install the well nuts as shown.

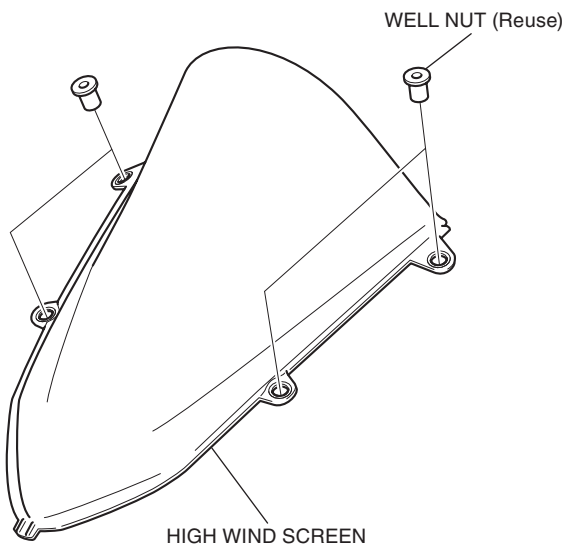

5. Install the high wind screen as shown.

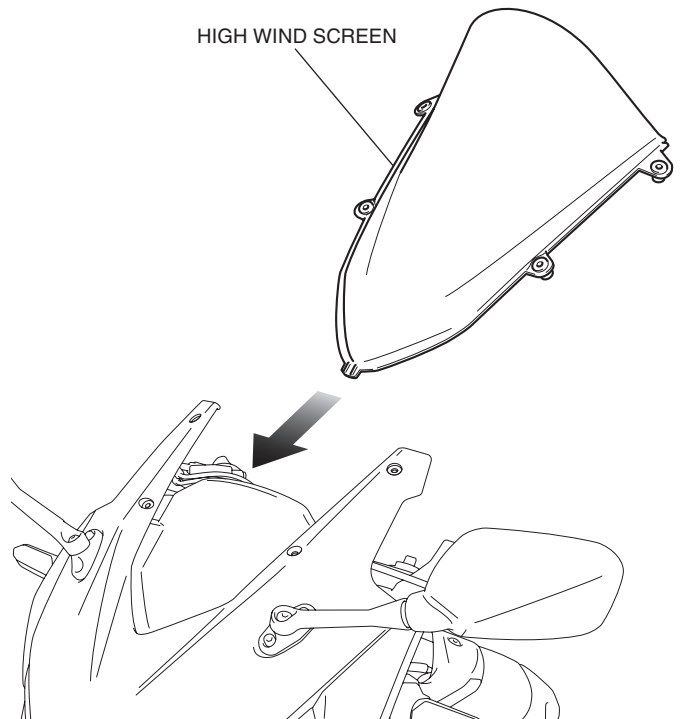

6. Install the parts as shown.

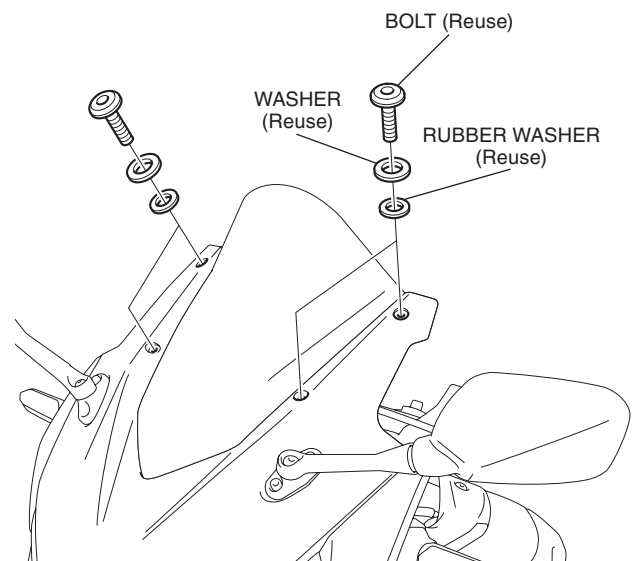

7. Attach the label in the position shown.

<Left side>

