



INSTALLATION INSTRUCTIONS

Accessory
WIDE MAIN STEP
P/N 08R72-MKC-AE0

Application
GL1800/B/BD/D/DA

Publication No.
MII
Issue Date
August 2019

Honda Dealer: Please give a copy of these instructions to your customer.

PARTS LIST

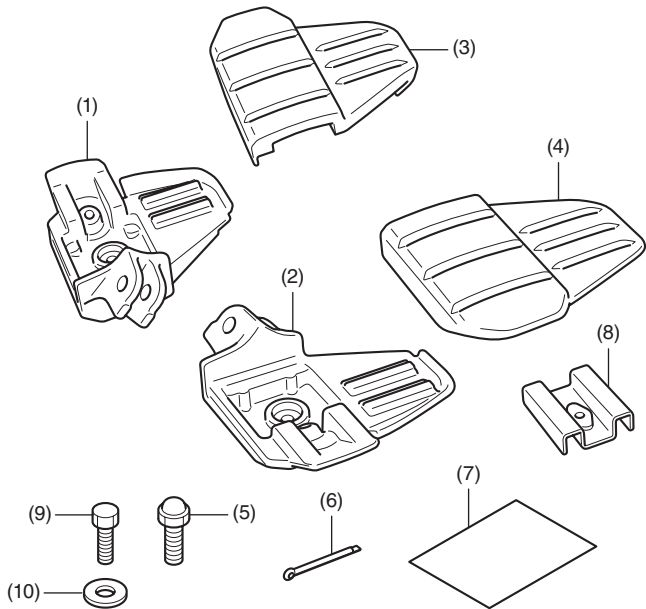

No.	Description	Qty
(1)	Right wide step arm	1
(2)	Left wide step arm	1
(3)	Right wide step rubber	1
(4)	Left wide step rubber	1
(5)	6 mm bolt	2
(6)	Split pin	2
(7)	Installation Instructions URL	1
(8)	Step set plate	2
(9)	5 mm bolt	2
(10)	Washer	4

TOOLS AND SUPPLIES REQUIRED

- Socket (8 and 10 mm)
- Ratchet
- Long nose pliers
- Grease
- Torque wrench

TORQUE CHART

Tighten all screws, bolts, and nuts to their specified torque values. Refer to the Service Manual for the torque values of the removed parts.

Item	N·m	kgf·m	lbf·ft
5 mm bolt	5.2	0.5	3.8
6 mm bolt	10	1.0	7

INSTALLATION

▲ CAUTION

- To prevent burns, allow the engine, exhaust system, radiator, etc., to cool before installing the accessory.

1. Remove the split pin and pivot pin as shown.

<Left side>

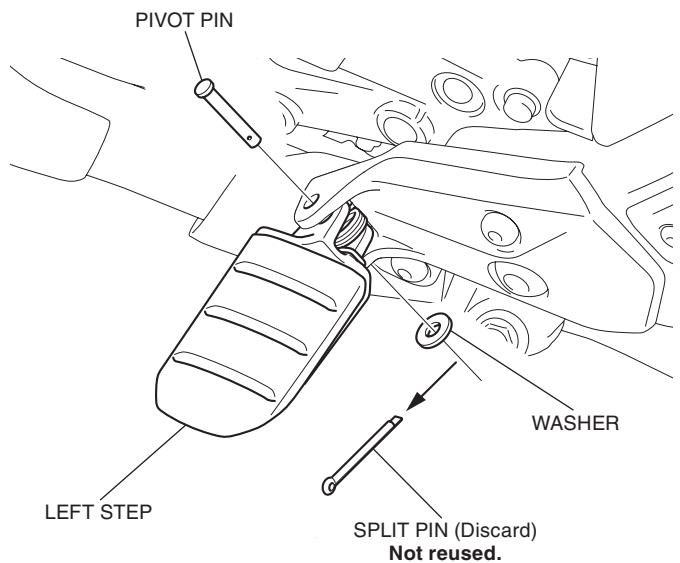

2. Remove the left step as shown.

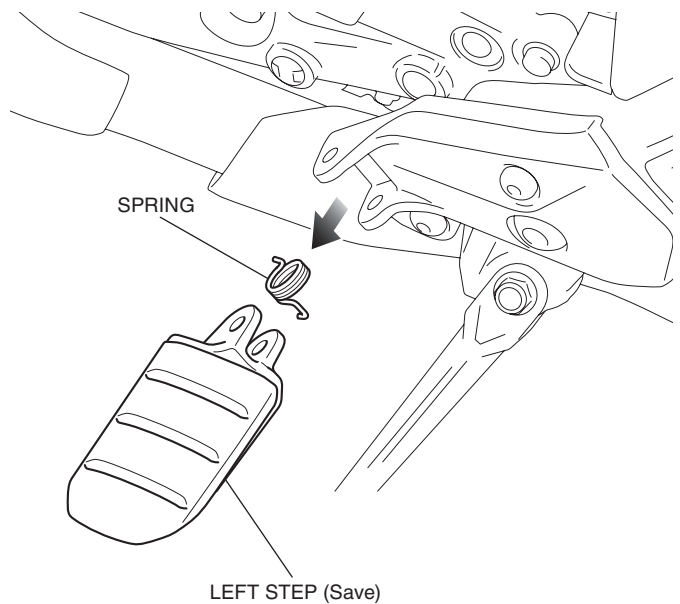

3. Assemble the step set plate and left wide step rubber as shown.

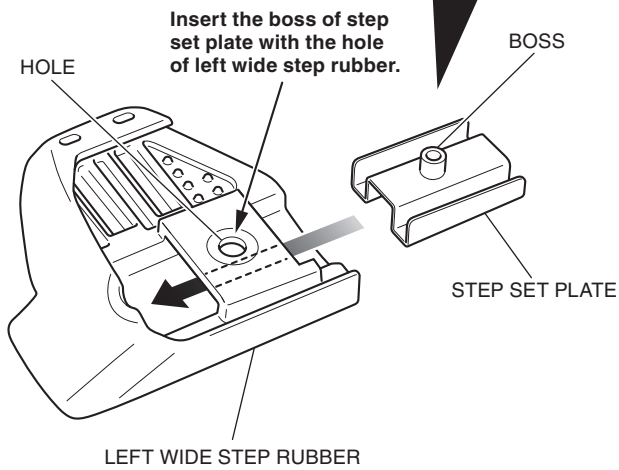
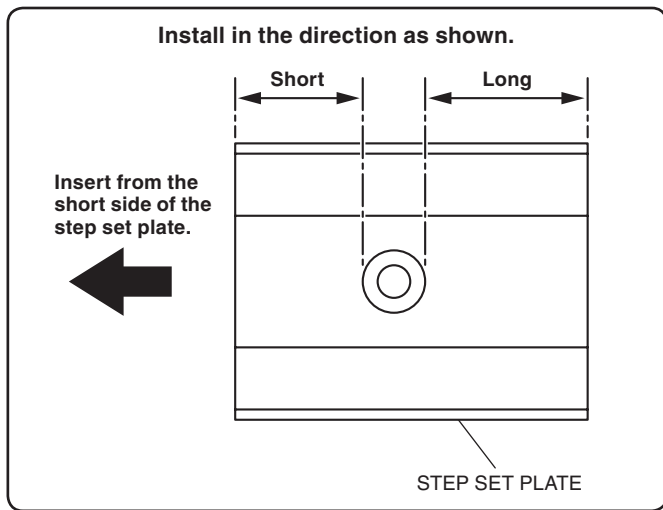

4. Set the washer in the position shown.

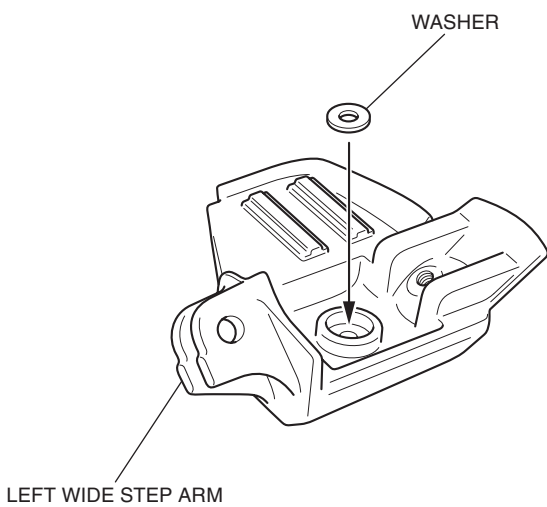

5. Install the left wide step arm to the assembled left wide step rubber as shown.

- Take care that none of the washer are dropped.

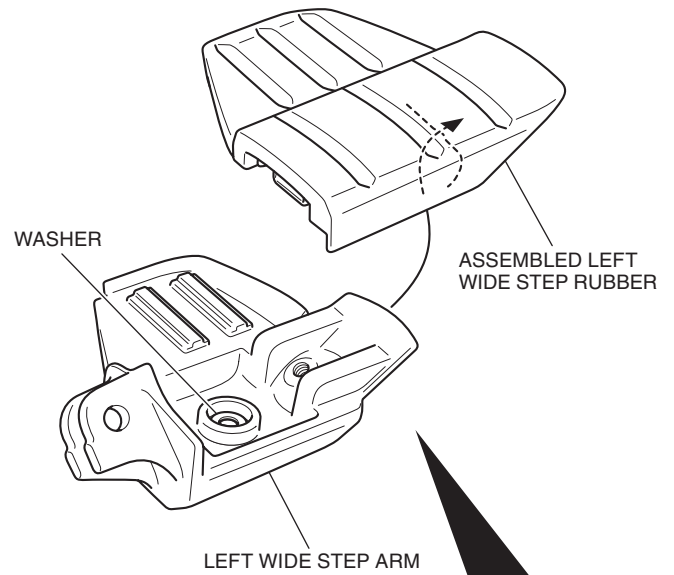

Place the  area of left wide step rubber on the left wide step arm.

<Backside>

LEFT WIDE STEP ARM LEFT WIDE STEP RUBBER

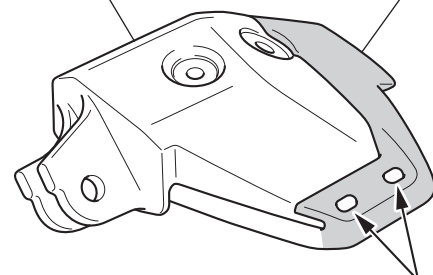

Align the hole of the left wide step rubber with the projected part of the left wide step arm.

6. Install the 5 mm bolt and 6 mm bolt as shown.

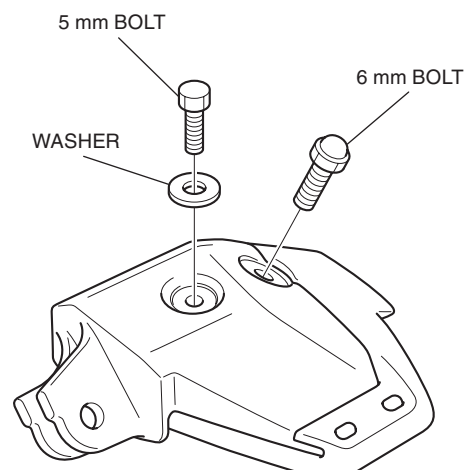

7. Apply grease to the positions shown.

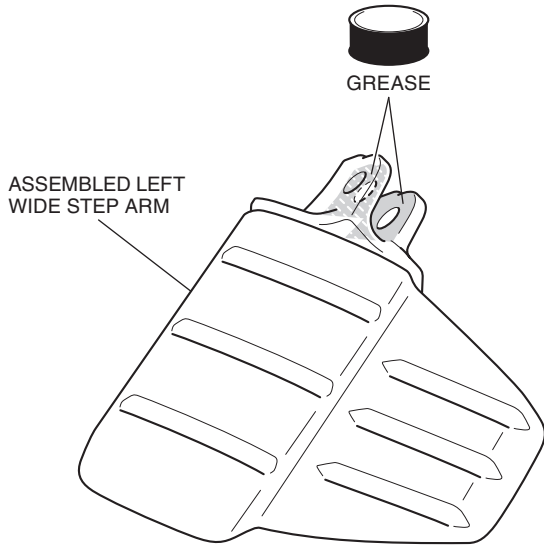

8. Install the spring as shown.

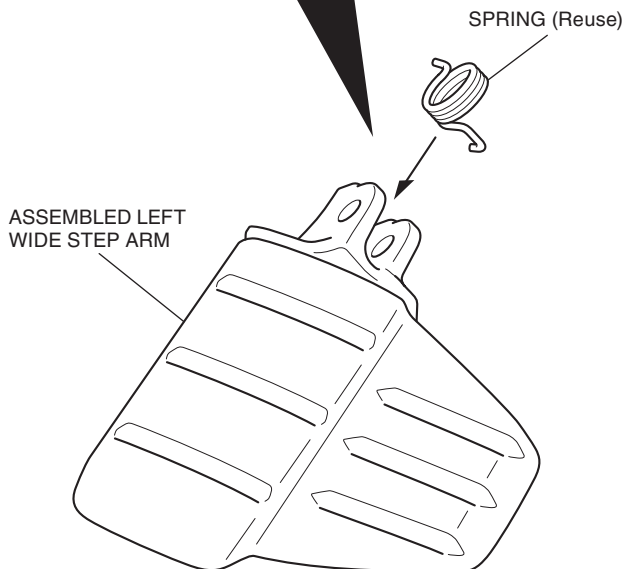
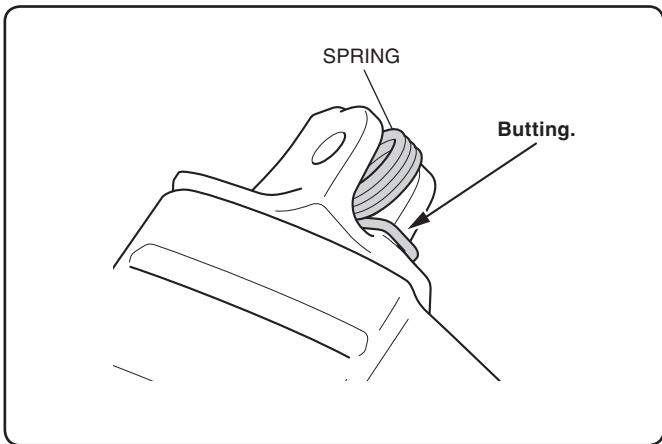

9. Apply grease to the pivot pin as shown.

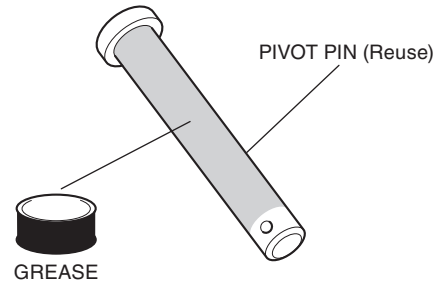

10. Install the assembled left wide step arm as shown.

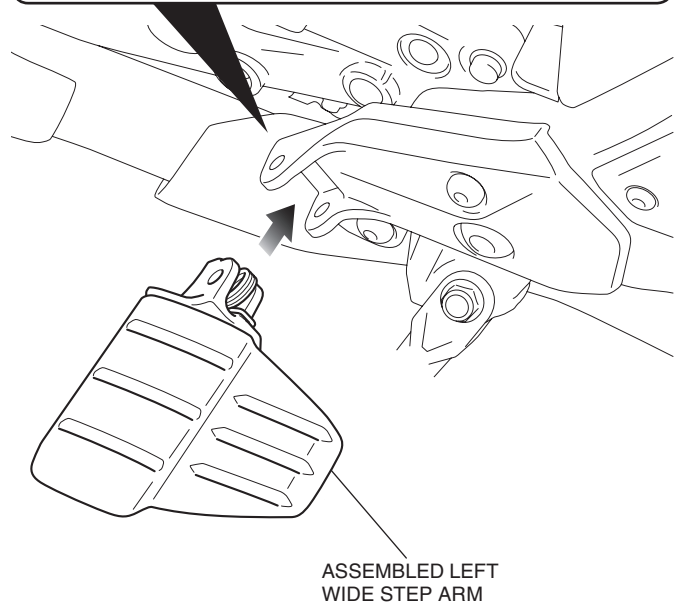
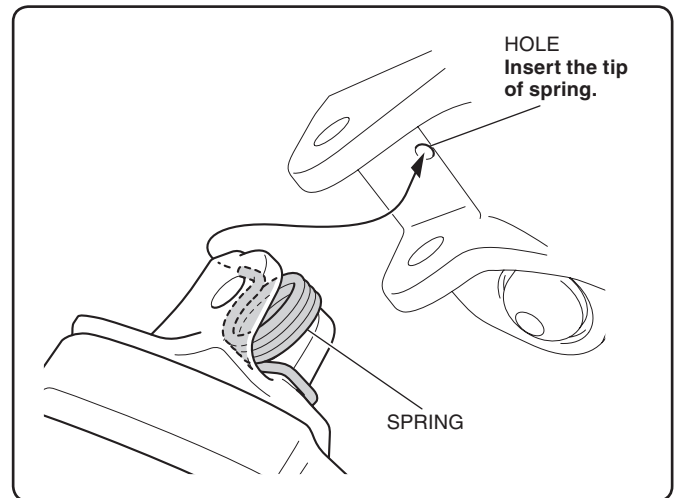

11. Install the pivot pin and split pin as shown.

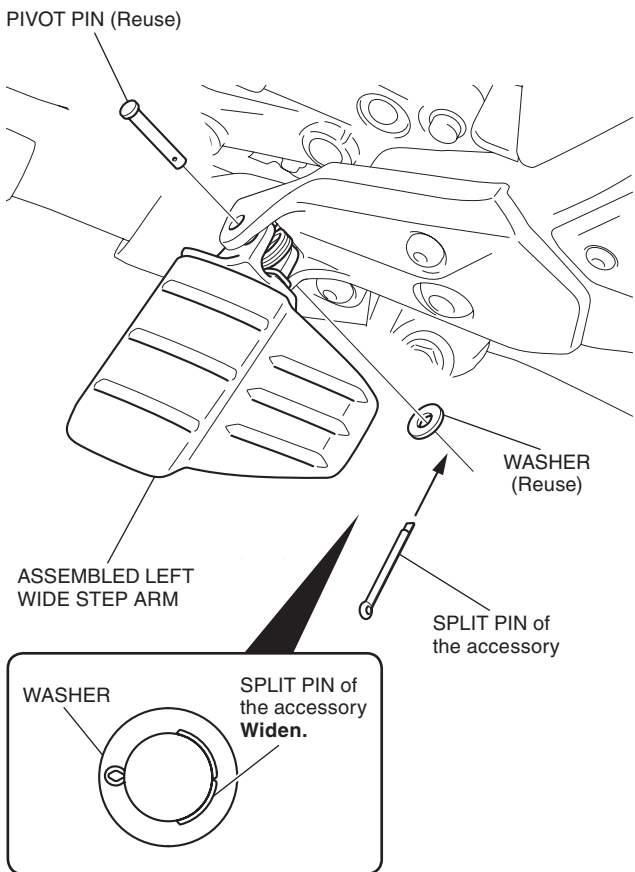

12. Check that the left wide step arm operates smoothly.

13. Repeat on the right side.

14. Adjust the height of change pedal with the nuts and rod as shown.

- Perform this step on GL1800/B only.

<Left side>

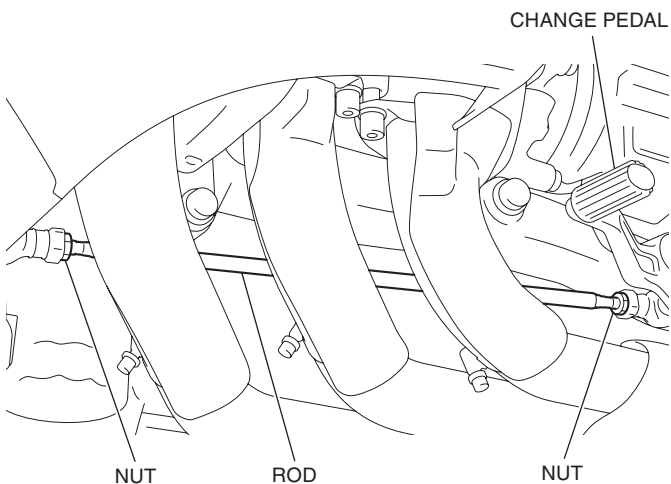

15. Adjust the height of brake pedal with the nuts as shown.

<Right side>

