



INSTALLATION INSTRUCTIONS

Accessory

PANNIER STAY
P/N 08L77-MKS-E00

Application

CRF1100A/A2/A4/D/D2/D4

Publication No.

MII

Issue Date

September 2019

Honda Dealer: Please give a copy of these instructions to your customer.

PARTS LIST

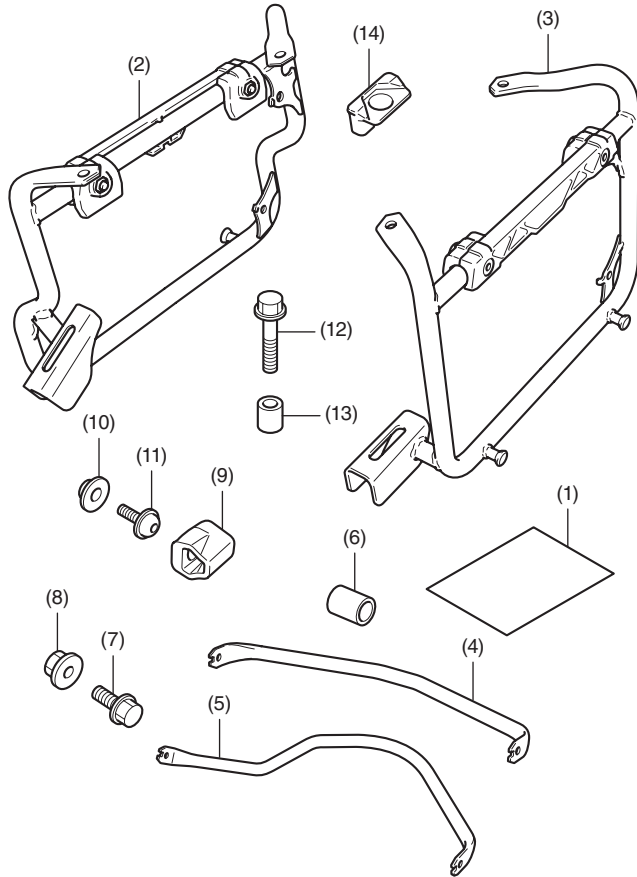

No.	Description	Qty
(1)	URL paper	1
(2)	Right pannier stay	1
(3)	Left pannier stay	1
(4)	Upper cross pipe	1
(5)	Lower cross pipe	1
(6)	Tube	1
(7)	8 mm SH flange bolt	4
(8)	8 mm flange nut	4
(9)	Rubber	2
(10)	Flange collar	2
(11)	5 mm socket bolt	2
(12)	8 mm flange bolt	4
(13)	Collar	4
(14)	Pannier stay cap	4

BOX ATTACHMENT

Sold separately

<CRF1100A/D only>

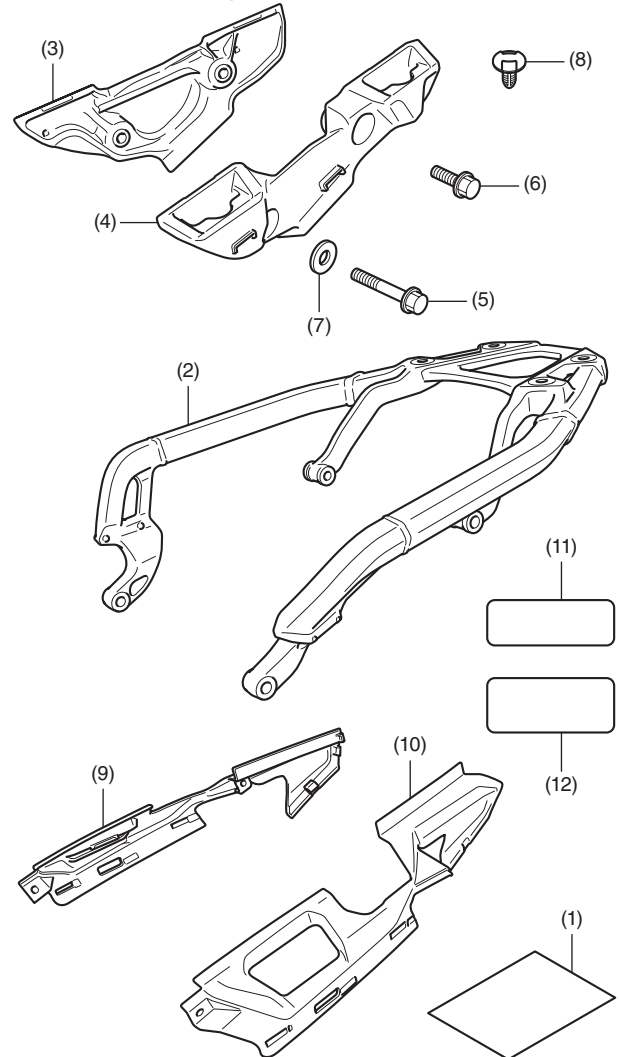

For the installation, refer to the Installation Instructions of accessory.

No.	Description	Qty
(1)	URL paper	1
(2)	Rear carrier	1
(3)	Right pannier bracket	1
(4)	Left pannier bracket	1
(5)	8 mm flange bolt	4
(6)	8 mm bolt	2
(7)	Washer	4
(8)	Clip	4
(9)	Right pannier bracket cover	1
(10)	Left pannier bracket cover	1
(11)	Label (MKK-D00)	1
(12)	Label (MFG-900)	1

TOOLS AND SUPPLIES REQUIRED

Socket (12 mm)
 Ratchet
 Box-end wrench (12 mm)
 Hex wrench (3 mm)
 Synthetic detergent solution
 (Water : Synthetic detergent / 100 : 1)
 Shop towel
 Torque wrench

TORQUE CHART

Tighten all screws, bolts, and nuts to their specified torque values. Refer to the Service Manual for the torque values of the removed parts.

Item	N·m	kgf·m	lbf·ft
5 mm socket bolt	5.2	0.5	3.8
8 mm flange bolt and nut	27	2.8	20

MAXIMUM LOADING CAPACITY

- The weight of the cargo must not exceed the following maximum loading capacity:

Maximum Loading Capacity	
Right pannier case	10.0 kg (22.0 lb)
Left pannier case	10.0 kg (22.0 lb)

INSTALLATION

⚠ CAUTION

- To prevent burns, allow the engine, exhaust system, radiator, etc., to cool before installing the accessory.

NOTE:

- When the motorcycle is equipped with the engine guard or front side pipe, install it first.
- Although the illustration is of CRF1100D4, use the same procedures for other models.

- Install the box attachment (sold separately).
 - Perform this step on CRF1100A/D only.**
- Insert the rubber as shown.

<Left side>

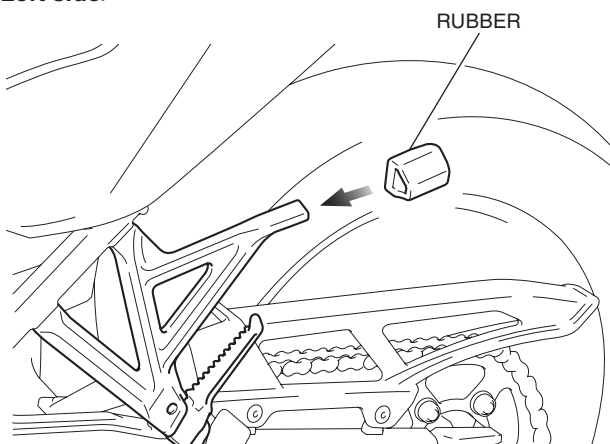

- Install the 5 mm socket bolt and flange collar as shown.

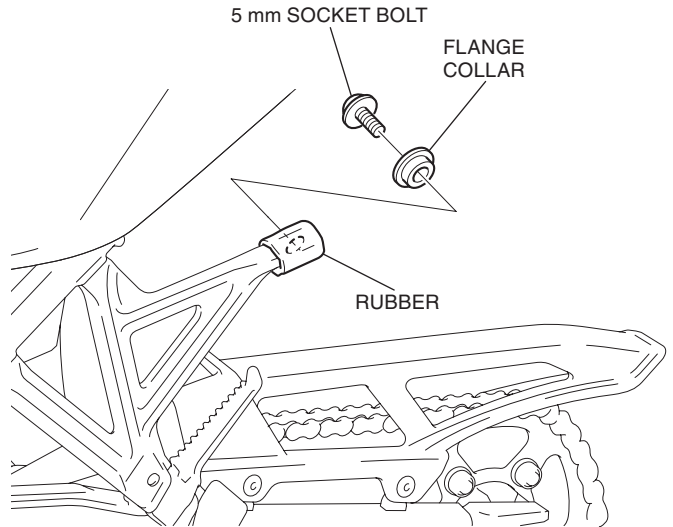

- Install the right side rubber in the same manner as the left side.
- Remove the clips as shown.
 - Repeat on the right side.**

<Left side>

CLIP (Save)
 Remove while turning.

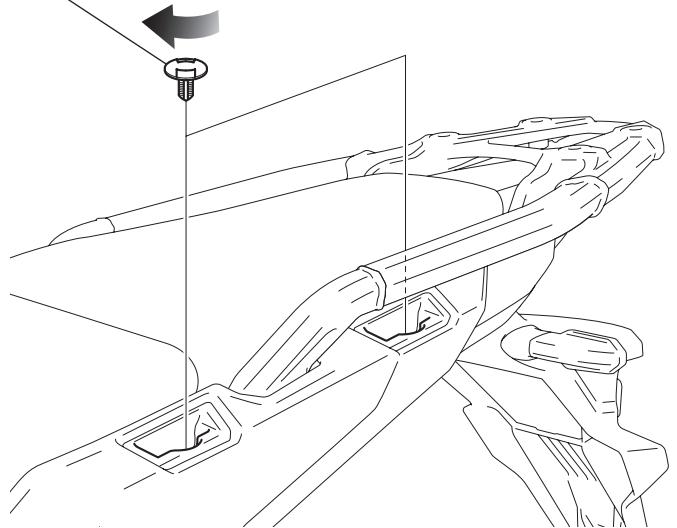

6. Install the pannier stay caps and collars as shown.
- Repeat on the right side.

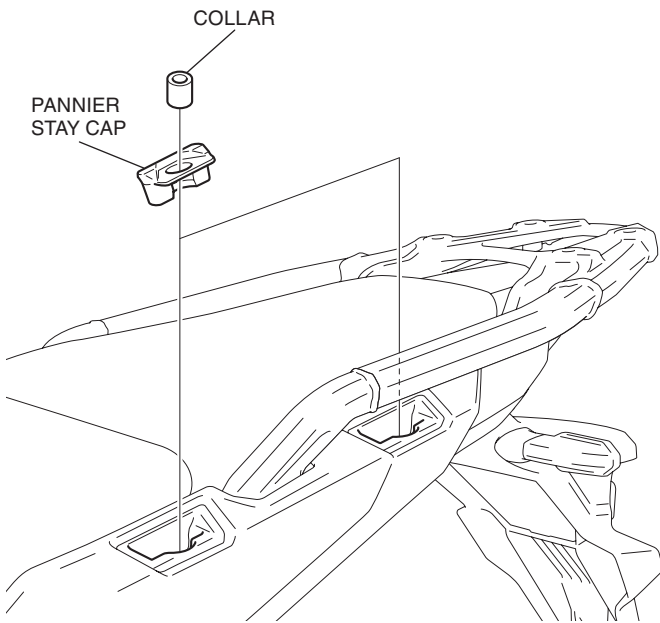

7. Install the left pannier stay as shown.
- First engage at the rubber and then install at the pannier stay caps.

<Left side>

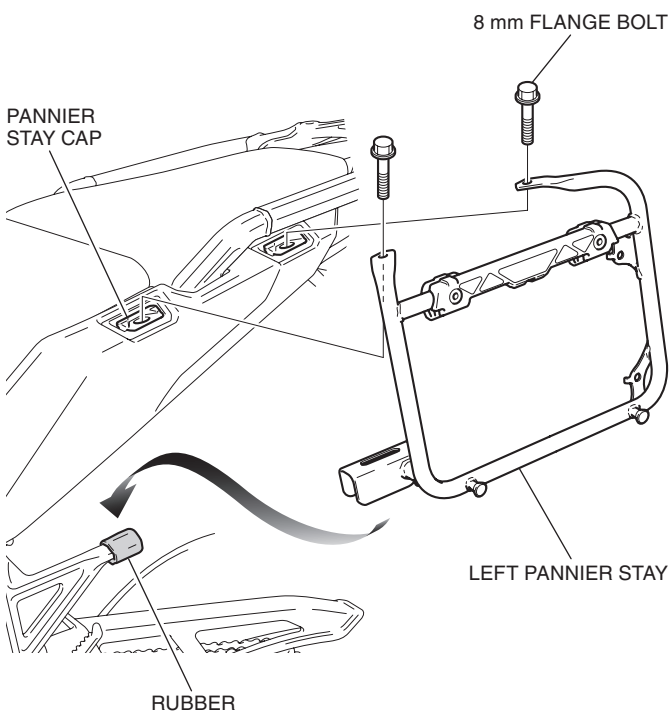

8. Install the right pannier stay in the same manner as the left side.

9. Apply synthetic detergent solution to the position shown.

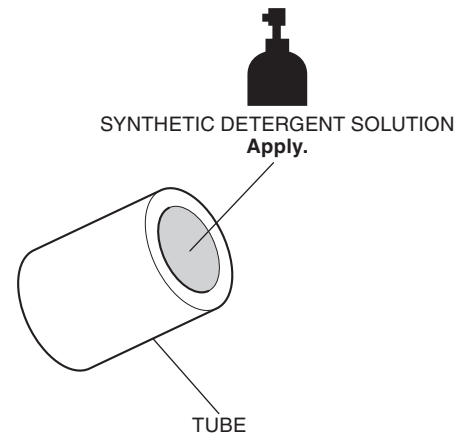

10. Install the tube as shown.

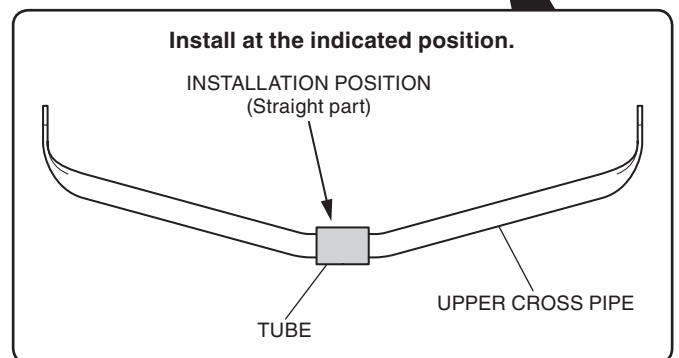
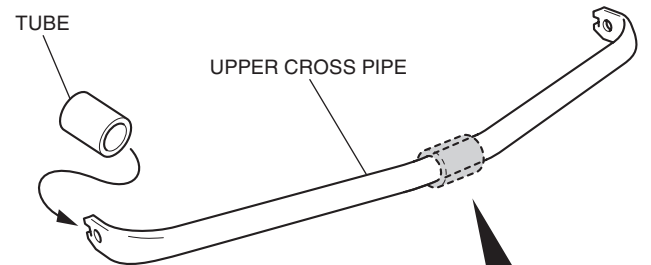

11. Loosely install the upper cross pipe as shown.

<Rear side>

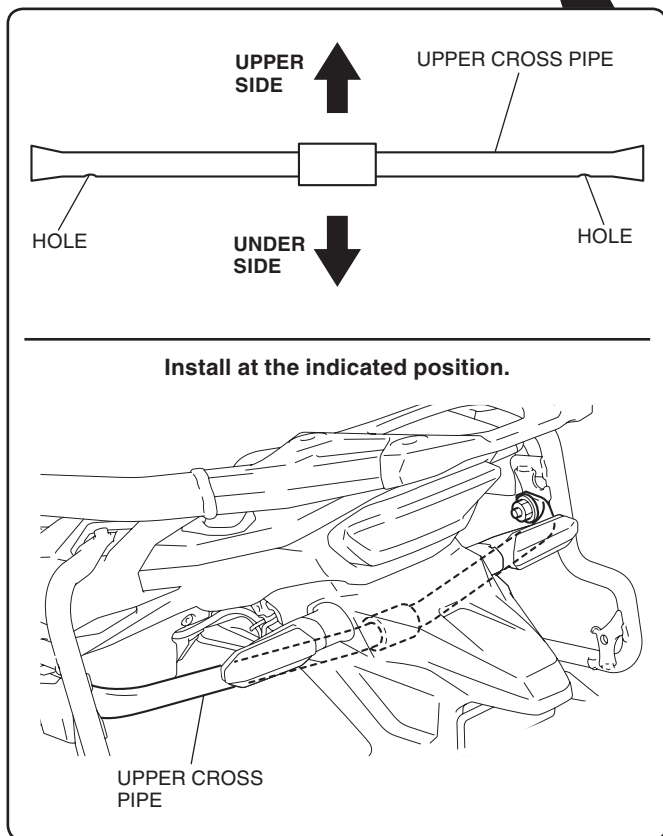
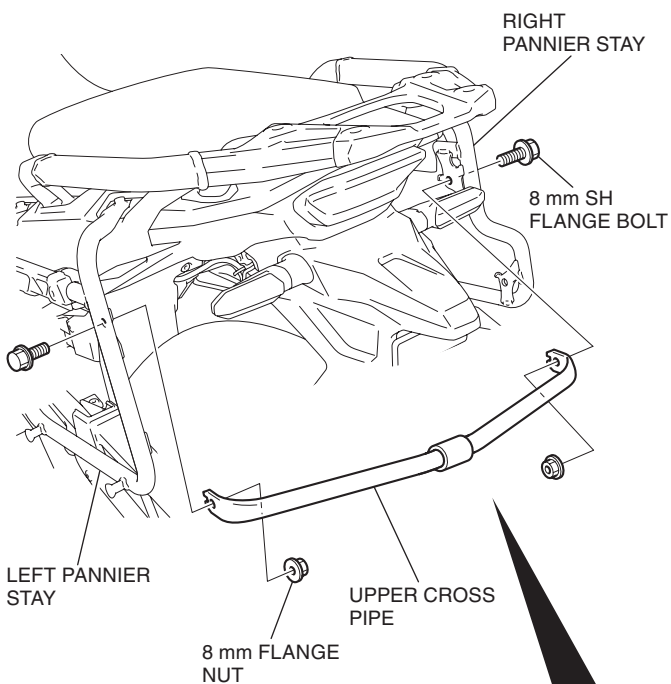

12. Loosely install the lower cross pipe as shown.

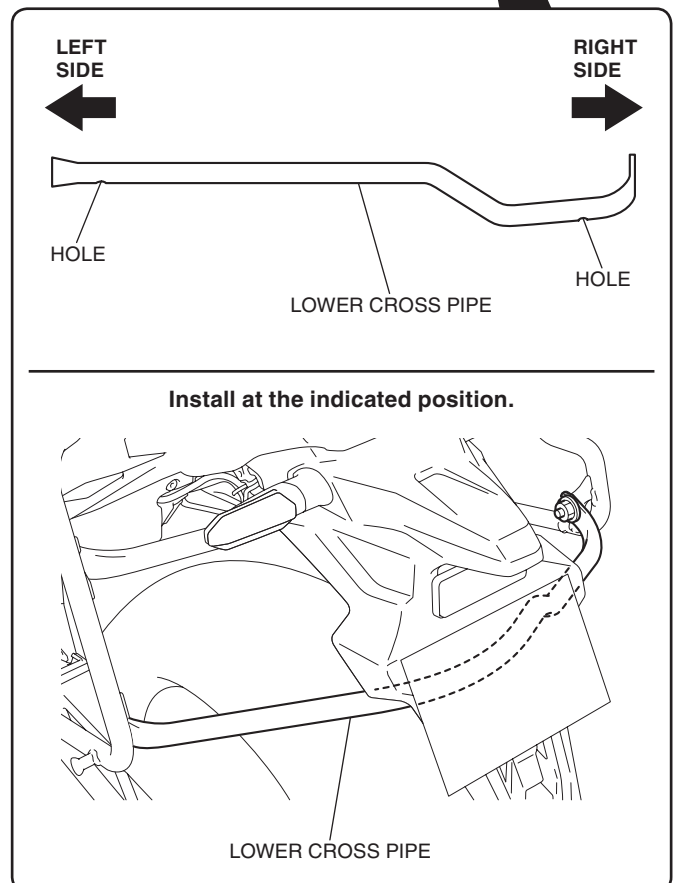
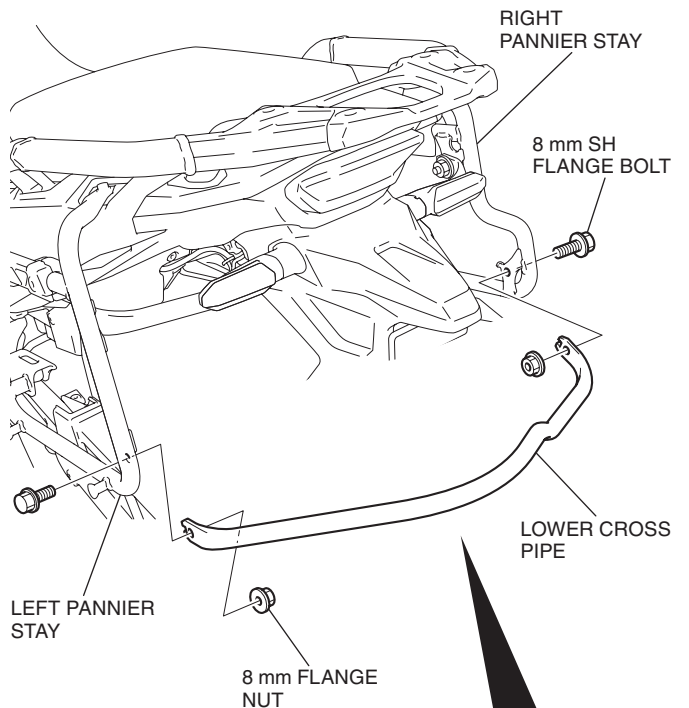

13. Tighten the loosely installed parts securely.

14. Refer to the Genuine Accessory user's Guide that comes together with the pannier case, and install the pannier case according to the instruction.