



INSTALLATION INSTRUCTIONS

Accessory

TANK BAG (4.5 L)
P/N 08L85-MKS-E00

Application

CRF1100A/A2/A4/D/D2/D4

Publication No.

MII

Issue Date

August 2019

Honda Dealer: Please give a copy of these instructions to your customer.

PARTS LIST

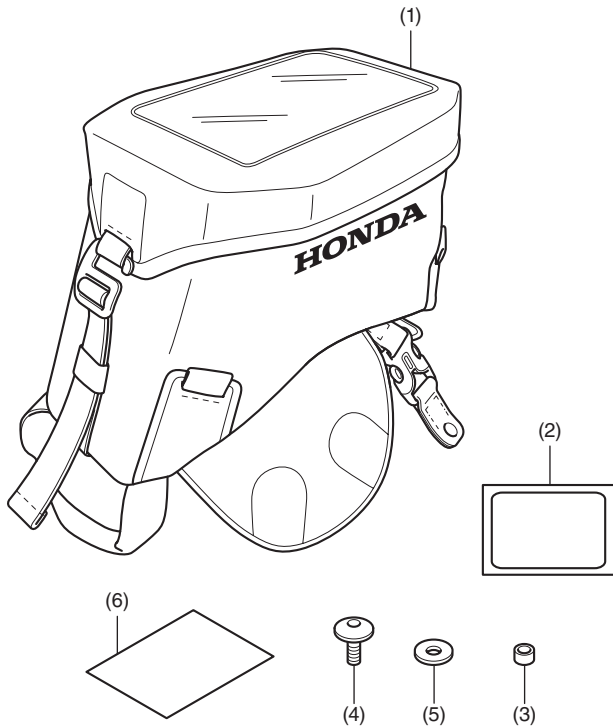

No.	Description	Qty
(1)	Tank bag	1
(2)	Protection film	2
(3)	Collar	2
(4)	6 mm screw	2
(5)	Washer	2
(6)	URL paper	1

TOOLS AND SUPPLIES REQUIRED

Hex wrench (5 mm)
Scissors
Tape
Isopropyl alcohol
Shop towel
Torque wrench

TORQUE CHART

Tighten all screws, bolts, and nuts to their specified torque values. Refer to the Service Manual for the torque values of the removed parts.

Item	N·m	kgf·m	lbf·ft
6 mm screw	10	1.0	7

MAXIMUM LOADING CAPACITY

- The weight of the cargo must not exceed the following maximum loading capacity:

Maximum Loading Capacity	
Tank bag	1.5 kg (3.3 lb)

INSTALLATION

NOTE:

- Heat the bonding surfaces with a hair dryer if the ambient air temperature is below 70°F (21°C).
- The adhesive reaches full strength in 72 hours. Wait at least 24 hours before riding your motorcycle.
- Before installation, remove all dust, sand, etc. from fuel tank and tank bag, as otherwise the fuel tank may be damaged.
- Although the illustration is of CRF1100D4, use the same procedures for other models.

- Remove the screws as shown.

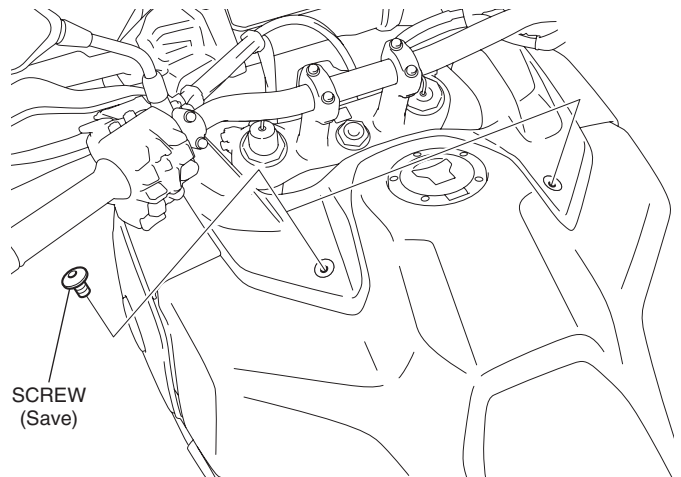

- Cut out the template along the solid line and attach it to the protection film.
 - Perform this step on CRF1100A2/A4/D2/D4 only.

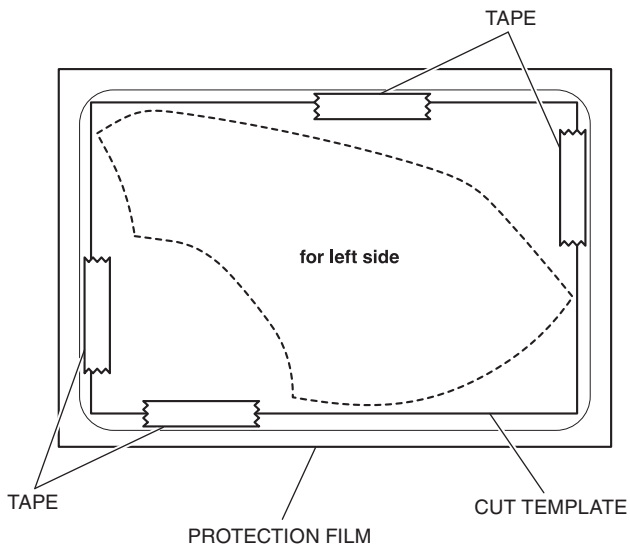

- Cut both the template and protection film together along the dotted line as shown.
 - Perform this step on CRF1100A2/A4/D2/D4 only.

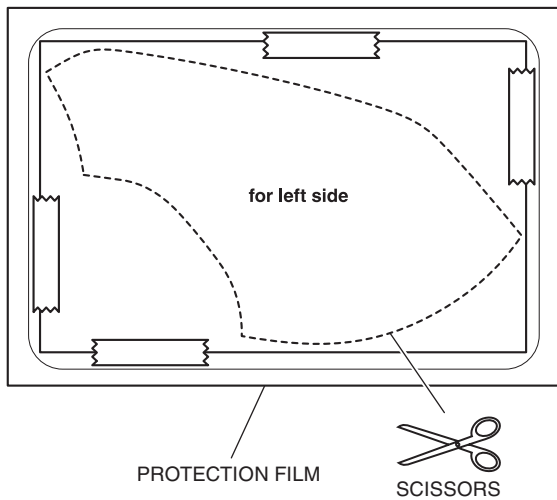

- Clean the surface of the area shown using an isopropyl alcohol.

<Left side> CRF1100A2/A4/D2/D4



<Left side> CRF1100A/D

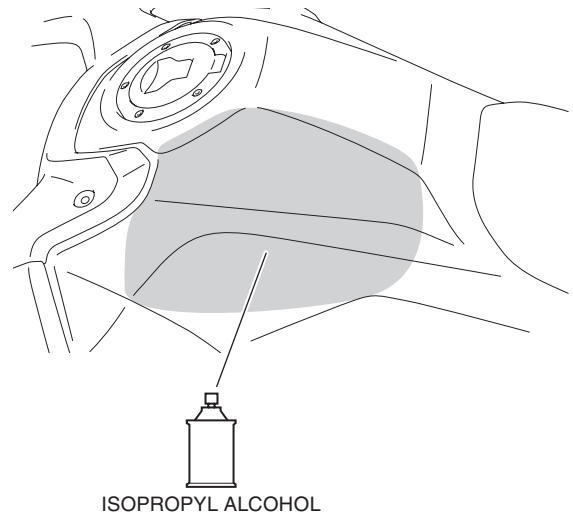

5. Attach the protection film to the fuel tank as shown.

PROTECTION FILM
Remove the adhesive backing before attaching.

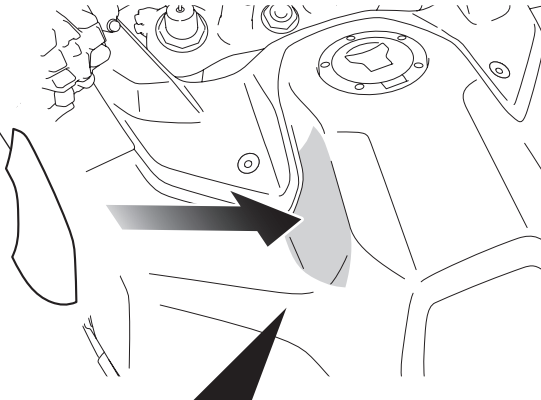

<CRF1100A2/A4/D2/D4>

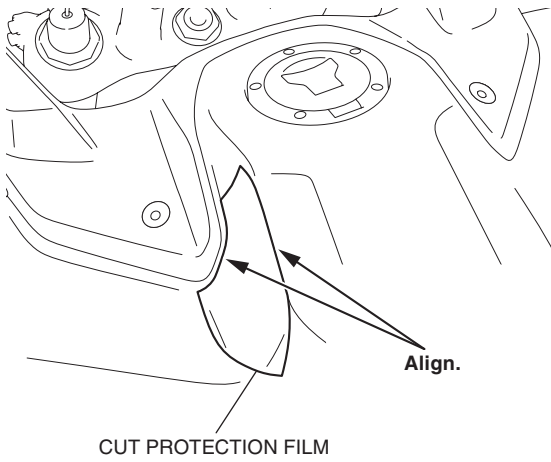

<CRF1100A/D>

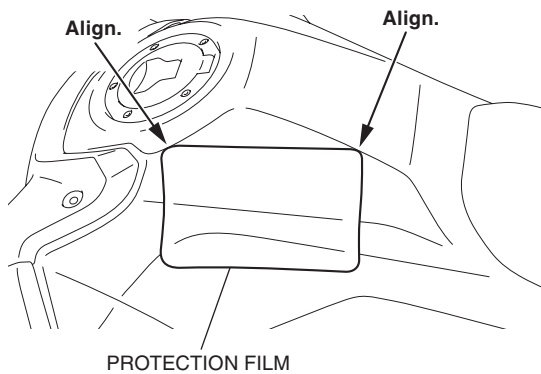

6. Install the right side of the protection film in the same manner as the left side.

7. Remove the straps as shown.

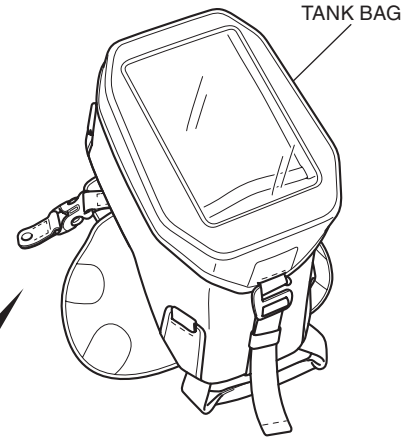

Remove the buckles as shown.

<Left side>

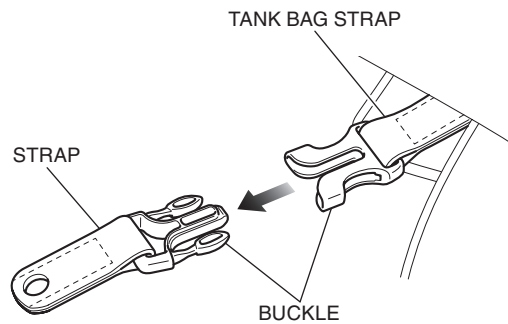

Repeat on the right side.

8. Install the strap as shown.

- Repeat on the right side.

<Left side>

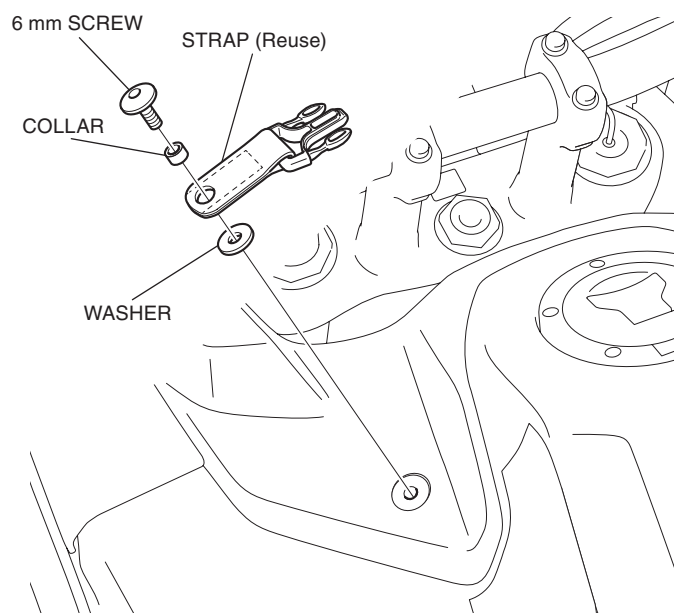

9. Install the tank bag on the fuel tank as shown.

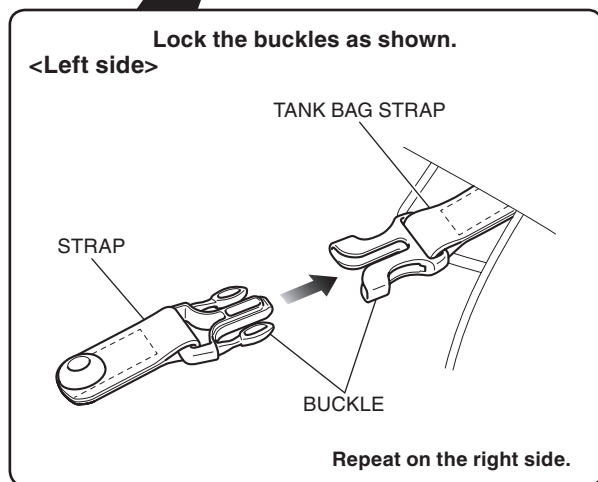
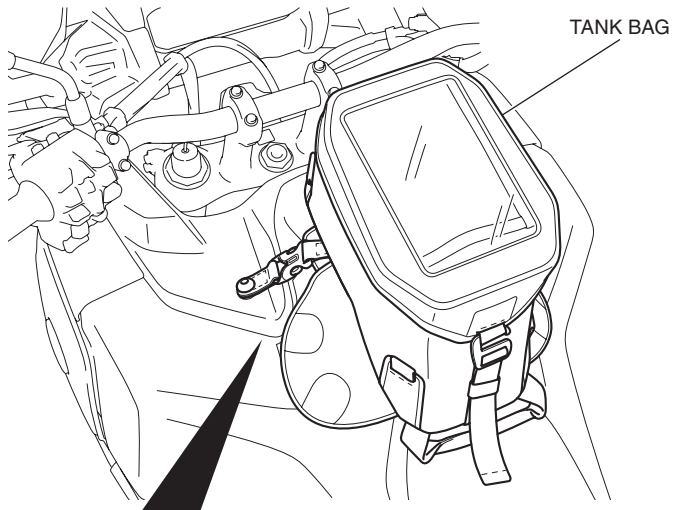

<TEMPLATE>

CRF1100A2/A4/D2/D4 only

