



INSTALLATION INSTRUCTIONS

Accessory PANNIER CASE P/N 08L72-MKT-D00	Application ADV750	Publication No. MII
		Issue Date October 2020

Honda Dealer: Please give a copy of these instructions to your customer.

PARTS LIST

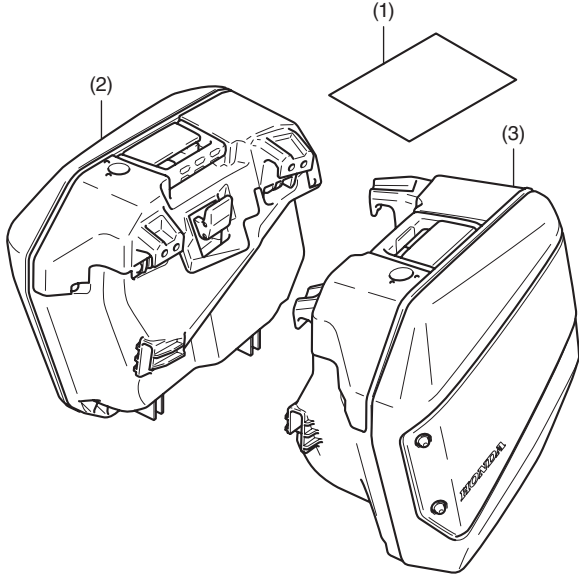

No.	Description	Qty
(1)	URL paper	1
(2)	Right pannier case	1
(3)	Left pannier case	1

1 KEY INNER CYLINDER (Wave key type)

Sold separately

- Do not use the [] slots.

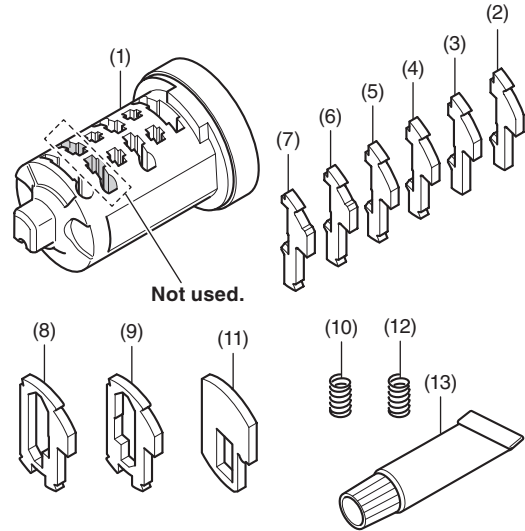

No.	Description	Qty
(1)	Inner cylinder	1
(2)	No.1 tumbler	6
(3)	No.2 tumbler	6
(4)	No.3 tumbler	6
(5)	No.4 tumbler	6
(6)	No.5 tumbler	6
(7)	No.6 tumbler	6
(8)	Sub-lock tumbler A	1
(9)	Sub-lock tumbler B	1
(10)	Spring (Silver)	13
(11)	Stopper tumbler	2
(12)	Stopper spring (Black)	2
(13)	Grease	1

PANNIER SUPPORT STAY

Sold separately

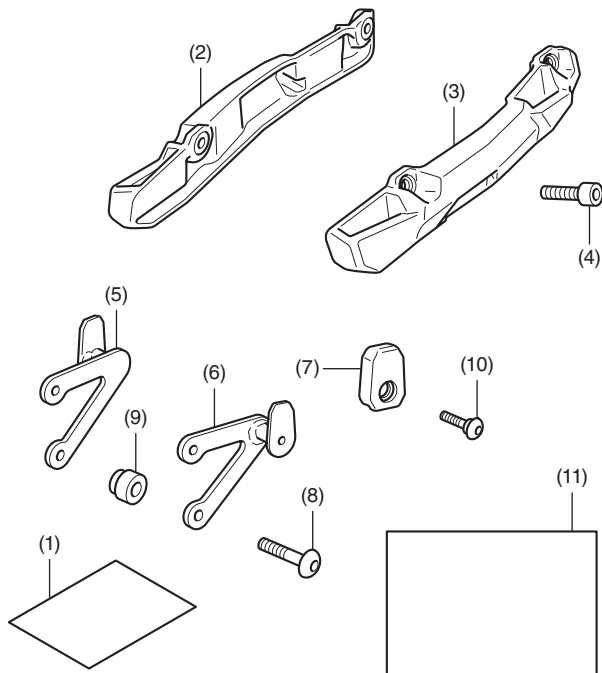

For the installation, refer to the Installation Instructions of accessory.

No.	Description	Qty
(1)	URL paper	1
(2)	Right pannier bracket	1
(3)	Left pannier bracket	1
(4)	8 mm socket bolt (short)	4
(5)	Right pannier support stay	1
(6)	Left pannier support stay	1
(7)	Rubber	2
(8)	8 mm socket bolt (long)	4
(9)	Collar	4
(10)	6 mm screw	2
(11)	Protector seal	1

REAR CARRIER

Sold separately

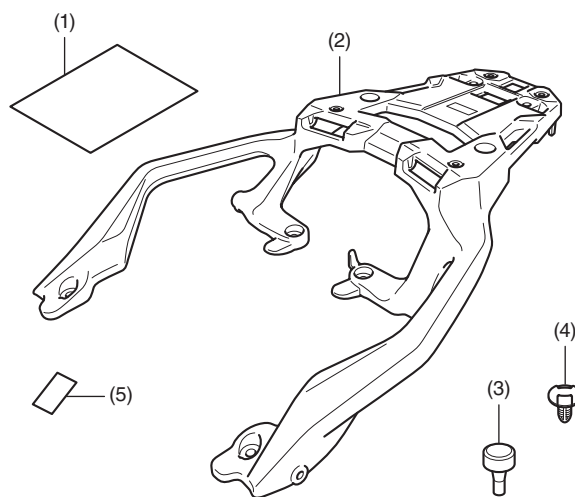

For the installation, refer to the Installation Instructions of accessory.

No.	Description	Qty
(1)	URL paper	1
(2)	Rear carrier	1
(3)	Stopper rubber	4
(4)	Clip (Not used.)	4
(5)	Protection film	2

MAXIMUM LOADING CAPACITY

- The weight of the cargo must not exceed the following maximum loading capacity:

Maximum Loading Capacity	
Right pannier case	6.0 kg (13.2 lb)
Left pannier case	6.0 kg (13.2 lb)

< Notes regarding the key cylinder >

- This product is used to assemble a key cylinder matching the motorcycle key by combining six types of tumblers.
- When this key cylinder is installed in a box or similar equipment, the installed equipment can be operated with the motorcycle key.

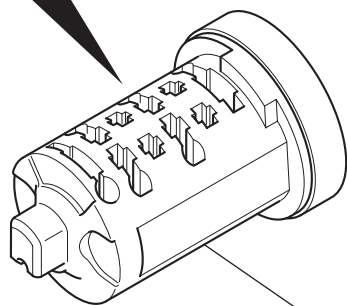
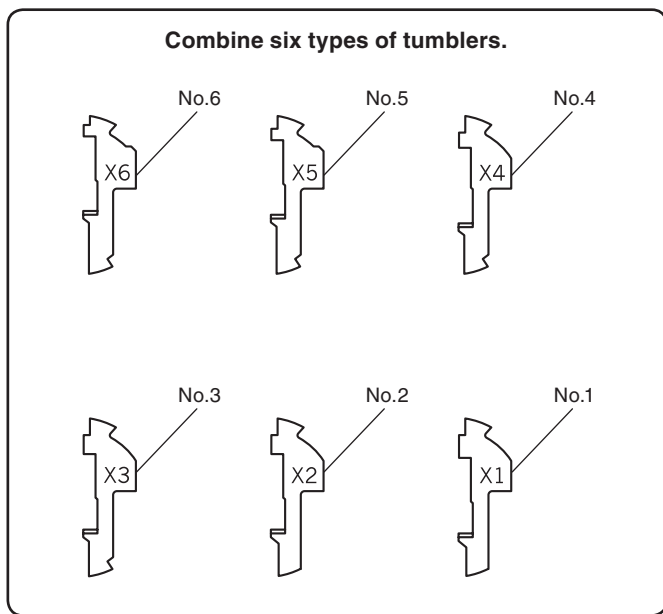

INNER CYLINDER

INSTALLATION

- The two sub-lock tumbler types shown are provided.
 - The  part has a different slot for each of the two sub-lock tumbler types.
 - As the tumblers are small, keep them in the bag until they are used.

SUB-LOCK TUMBLER A

SUB-LOCK TUMBLER B

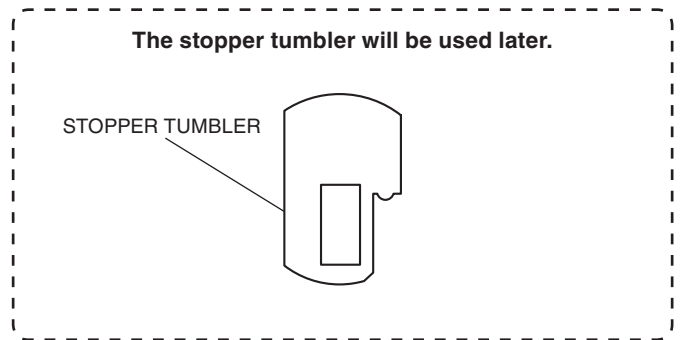
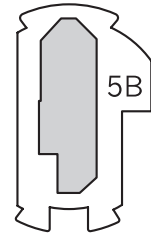
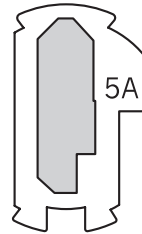

- The six tumbler types shown are provided.
 - The  part has a different width for each of the six tumbler types.
 - As the tumblers are small, keep them in the bag until they are used.

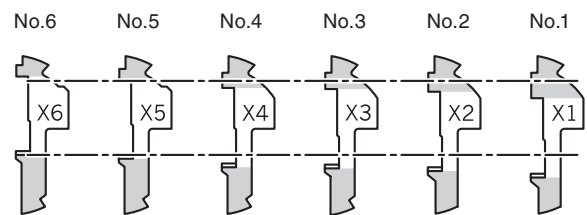

3. Install the tumblers and springs (silver) as shown.
- **First install four No.1 tumblers.**
 - **Note the installed tumbler to below chart.**

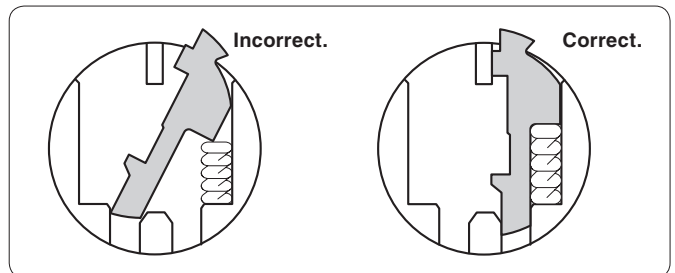
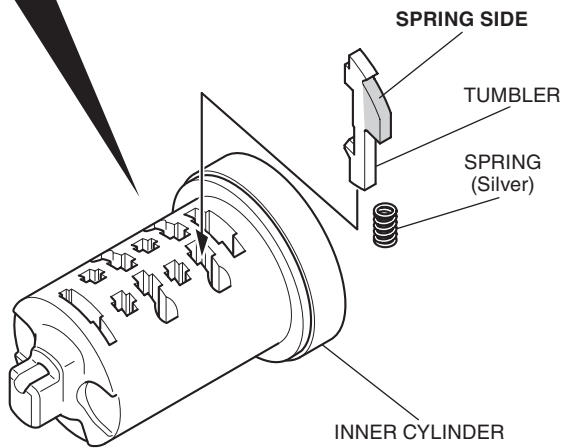
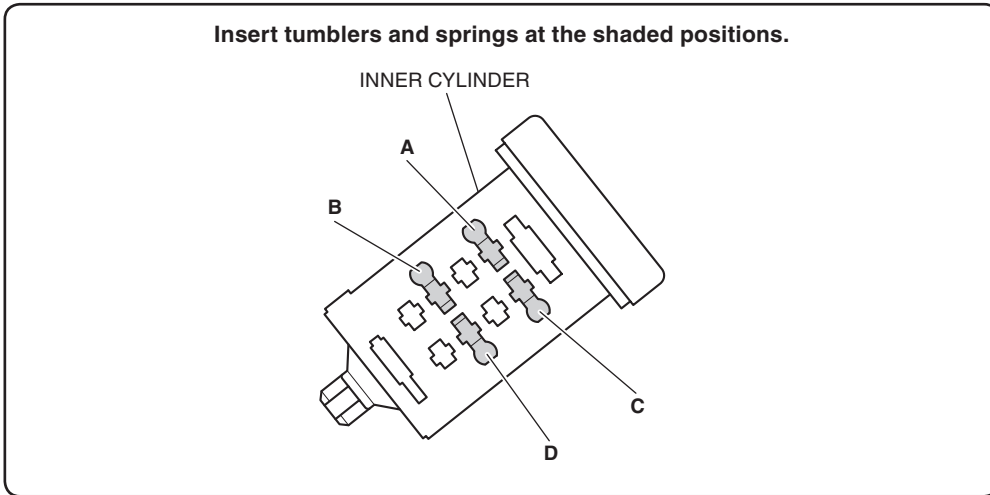

	Position A	Position B	Position C	Position D
No.1 tumbler				
No.2 tumbler				
No.3 tumbler				
No.4 tumbler				
No.5 tumbler				
No.6 tumbler				

4. Insert the key as shown.
 - **Lightly press down on the tumblers from above, then insert the key.**

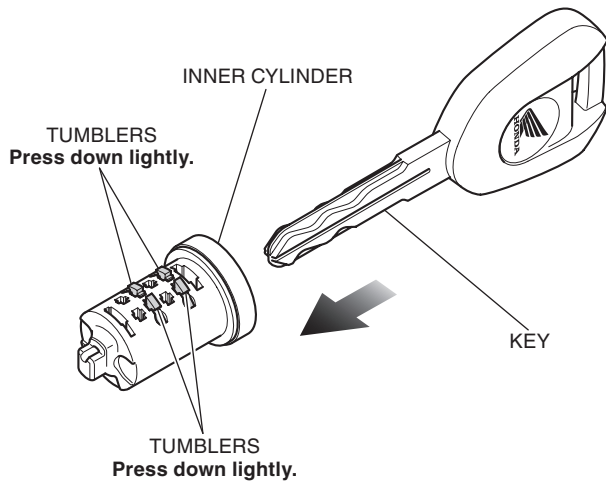

5. Confirm that some tumblers are projecting. Mark the positions of the projected tumblers.
 - **The positions where tumblers project and the projecting height differ according to the key.**

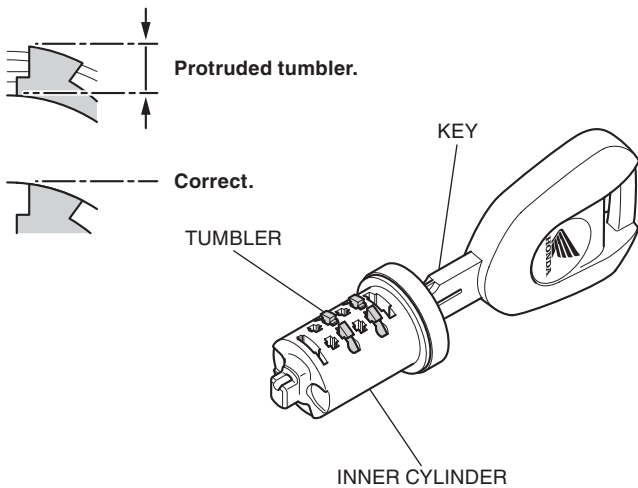

6. Press down lightly on the tumbler, pull the key out.
 - **The tumbler spring may jump out when the tumbler is not pressed down lightly.**

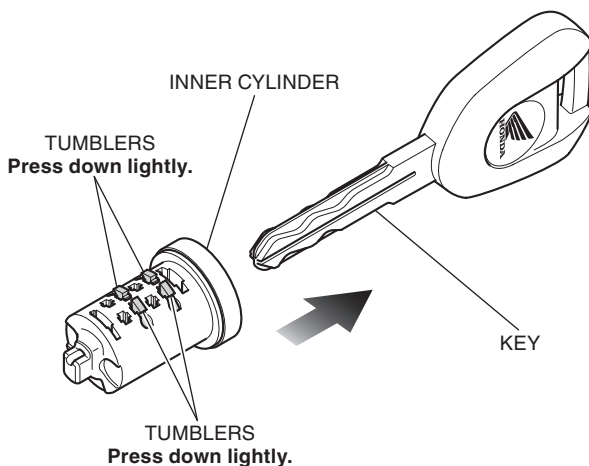

7. Pull out the projecting tumbler(s).
 - **Leave the spring(s) installed.**

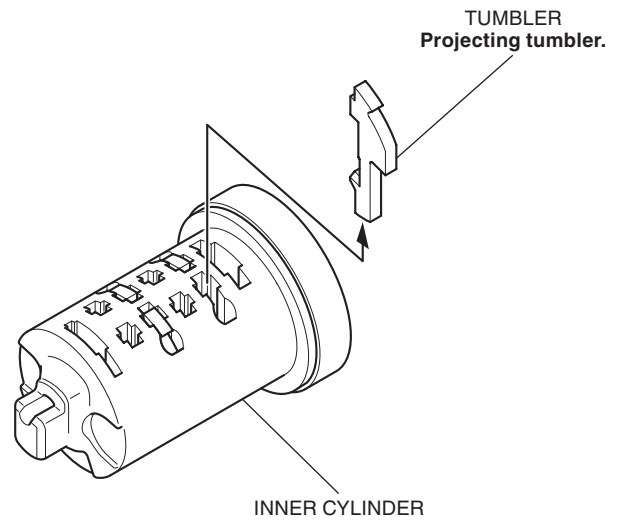

8. Insert a different tumbler(s) at the marked positions.
 - **Use a tumbler of young number one stage.**

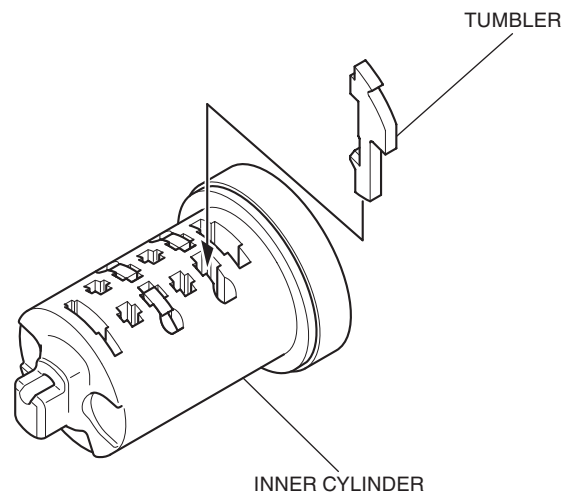

9. Repeat steps 4 to 8, inserting different tumblers at the marked positions until no tumblers are projected.
 - **Lightly press down on the tumblers from above, then insert the key.**

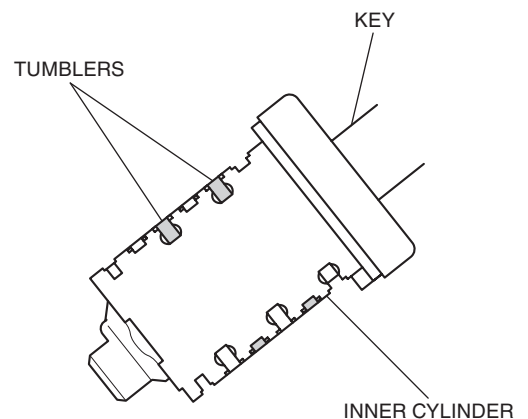

10. Install the tumblers and springs (silver) to the reverse side inner cylinder as shown.

- **First install two No.1 tumblers.**

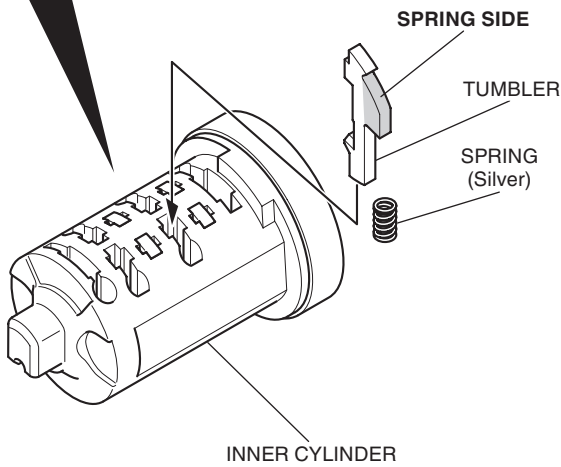
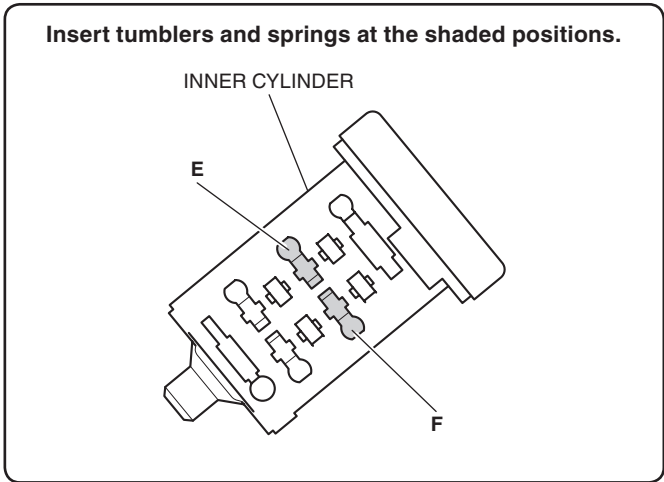

- **Note the installed tumbler to below chart.**

	Position E	Position F
No.1 tumbler		
No.2 tumbler		
No.3 tumbler		
No.4 tumbler		
No.5 tumbler		
No.6 tumbler		

11. Use steps 4 through 8 to assemble the reverse side inner cylinder in the same manner.

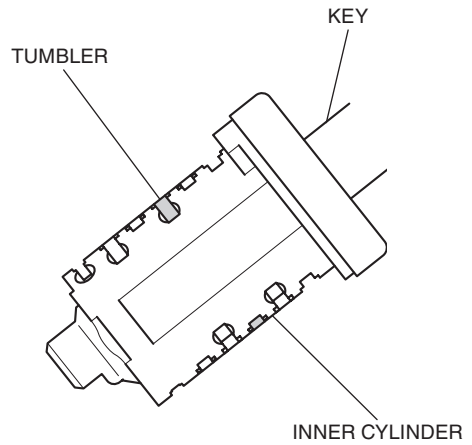

12. Install the sub-lock tumbler as shown.

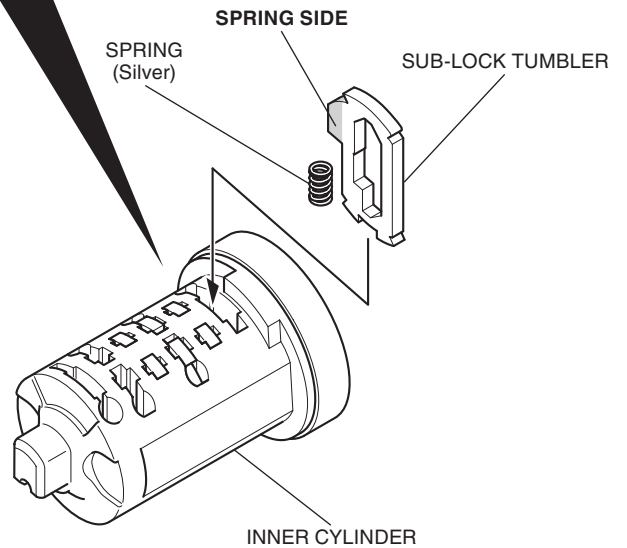
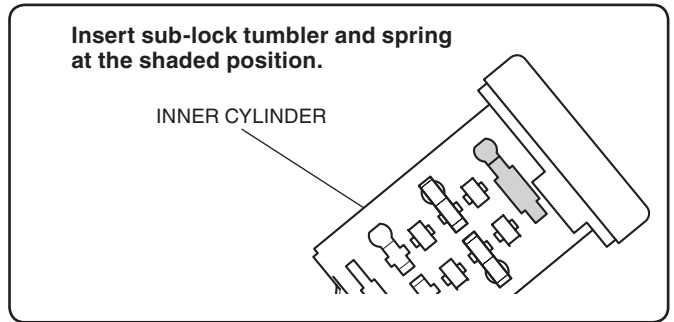

- **Note the installed tumbler to below chart.**

Sub-lock tumbler A	
Sub-lock tumbler B	

13. Confirm that sub-lock tumbler is not projecting.
- **If the tumbler is projected, change the another sub-lock tumbler and recheck.**

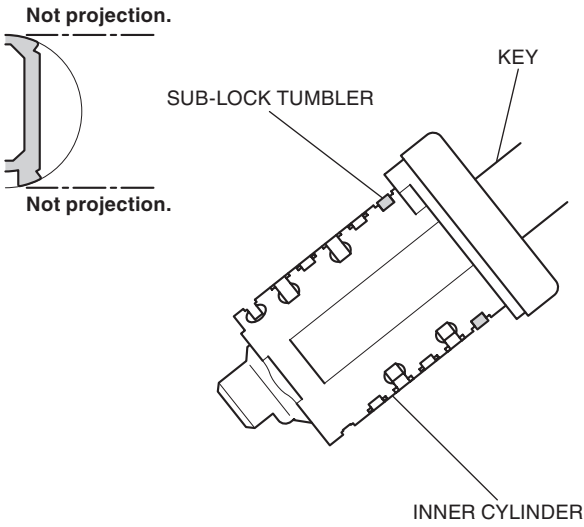

14. Insert the assembled inner cylinder into the key cylinder as shown.
- **Confirm the inner cylinder turns clockwise smoothly.**

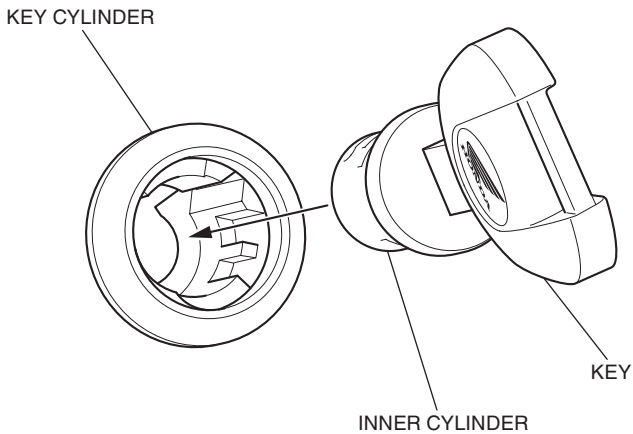

15. Pull out the inner cylinder.
16. Press down lightly on the tumblers and pull out the key.

17. Install the stopper tumbler and stopper spring (black) as shown.

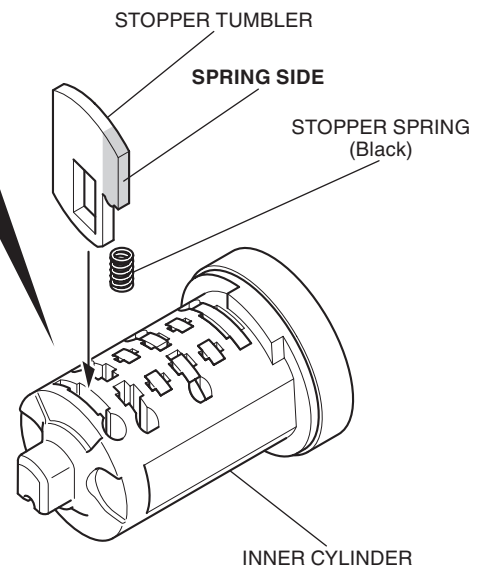
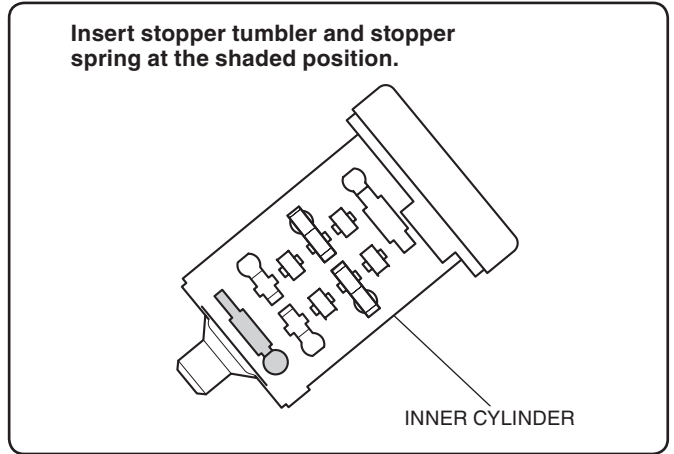

18. Insert the key as shown.
- **Lightly press down on the tumblers from above, then insert the key.**
 - **Confirm that the stopper tumbler jumps out.**

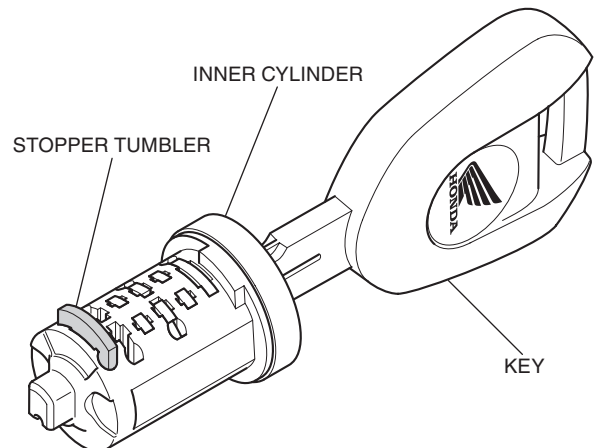

19. Apply grease to the shaded areas as shown.
- Apply to the tumbler and to the outer circumference of the inner cylinder.
 - Only use the supplied grease.

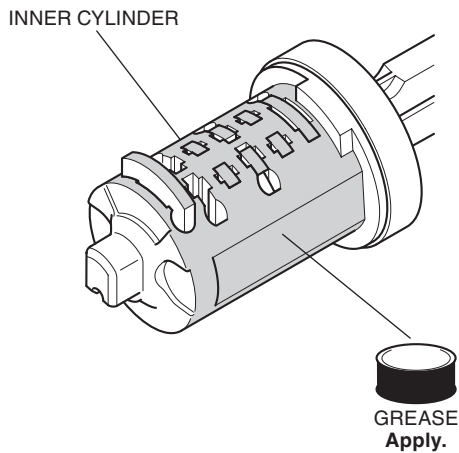

20. Install the inner cylinder by sliding the stopper tumbler along the slide guide while rotating it.
- If the inner cylinder cannot be inserted, again confirm that no tumblers other than the stopper tumbler have jumped out.

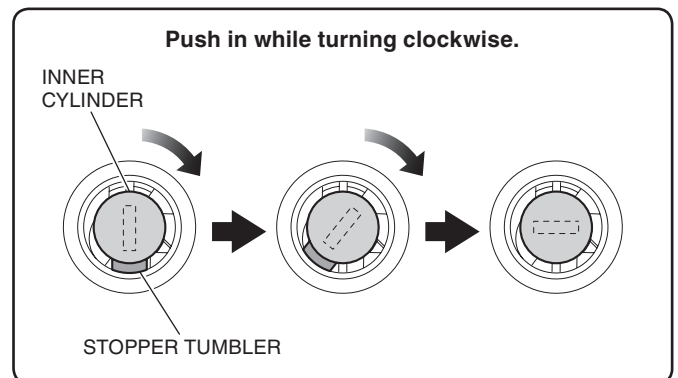
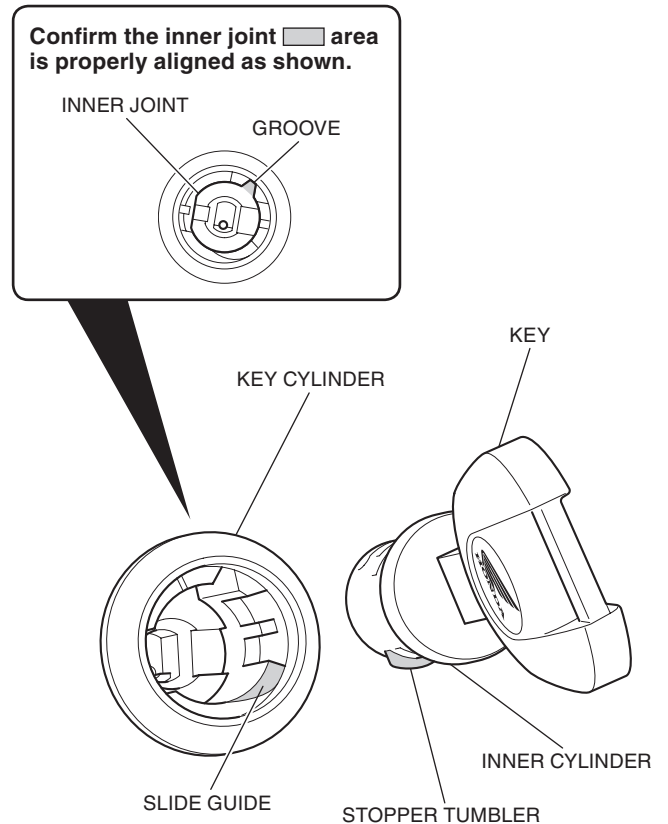

21. Draw out the key and check that the inner cylinder does not come out.
22. Install the inner cylinder to other body in the same manner.

FOR USE OF THE PANNIERS

⚠ CAUTION

- To prevent burns, allow the engine, exhaust system, radiator, etc., to cool before installing and removing the accessory.

How to Open the Panniers

1. Insert the key and release the lock by turning the key clockwise.

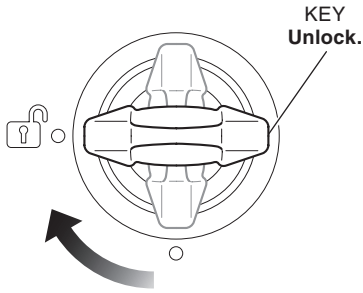

2. Pull the plate lock to open the lid as shown.

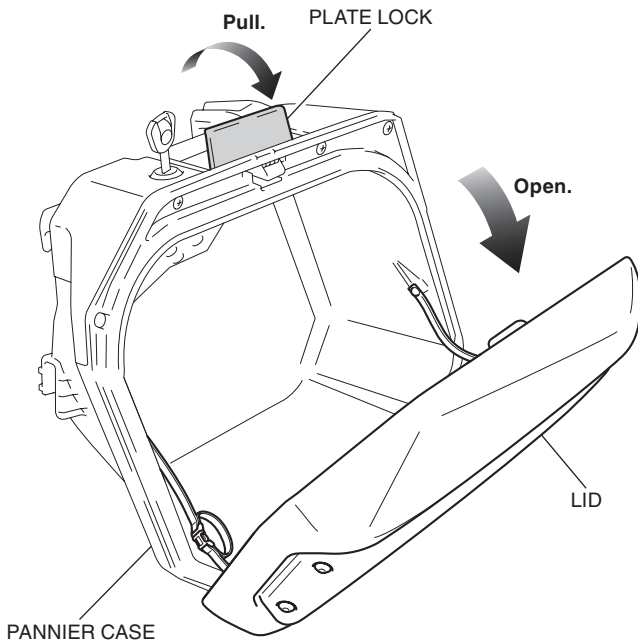

How to Close the Panniers

1. Close and lock the panner case in reverse order of opening.
 - Be careful not to have the stored item pinched when the panner case is closed.

How to Install the Panniers

1. Install the rear carrier (sold separately).
2. Install the panner support stay (sold separately).
3. Insert the key and release the lock by turning the key clockwise.

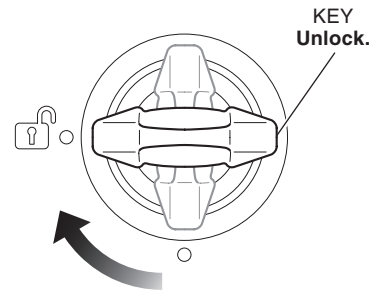

4. Raise the handle lever as shown.

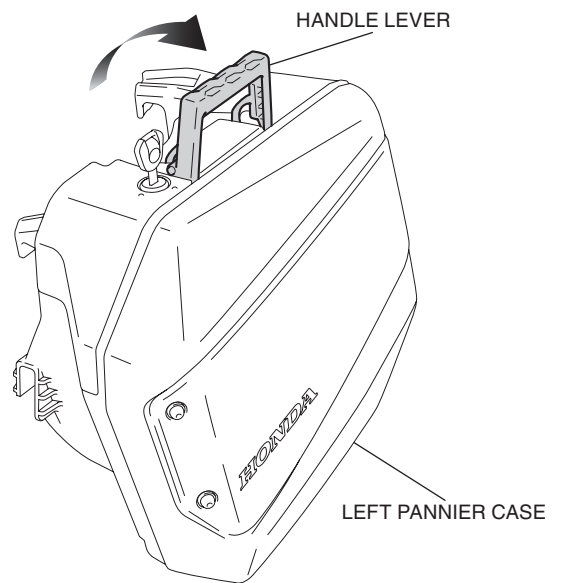

5. Install the left pannier case as shown.
 - First engage at the rubber and then install at the two holes.

<Left side>

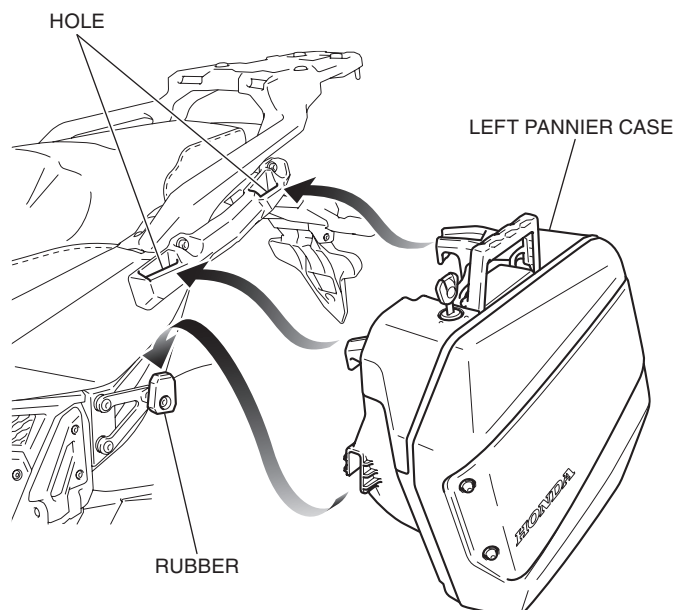

6. Push down the left pannier case as shown.

Make sure that the rubber part of the pannier case is in contact with the pannier bracket.

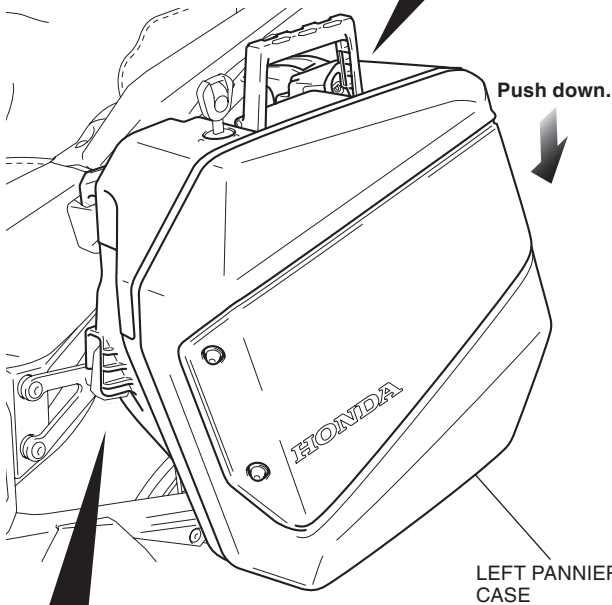
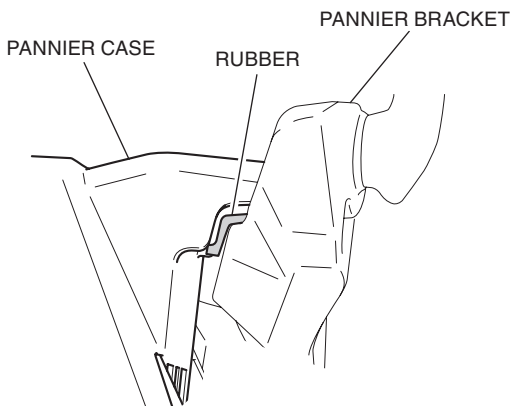

Make sure that the rubber is in contact with the pannier case.

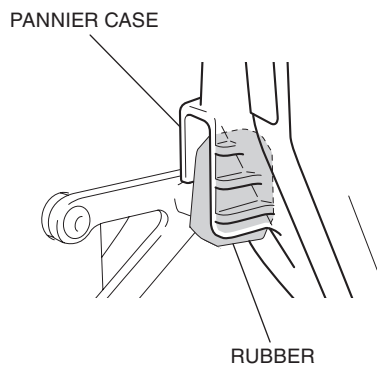

7. Lower the handle lever as shown.

Confirm that the hook is securely attached.

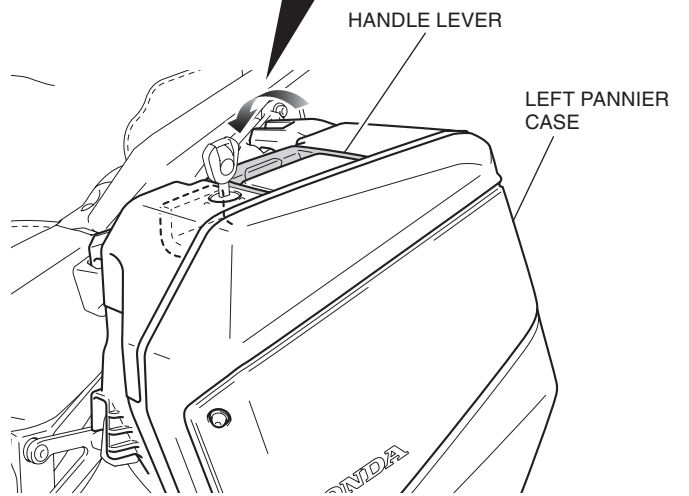
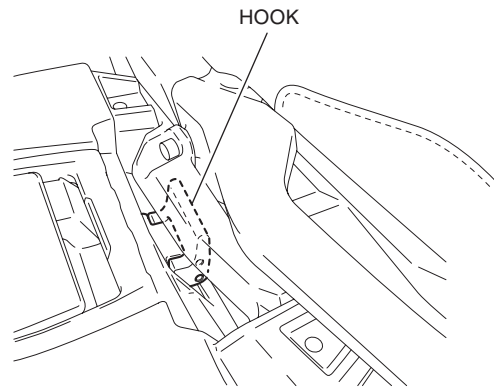

8. Lock the pannier by turning the key counter-clockwise.

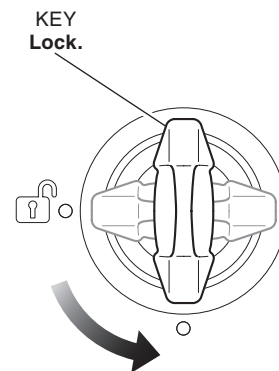

9. Remove the key. Be sure that the handle lever cannot be released.

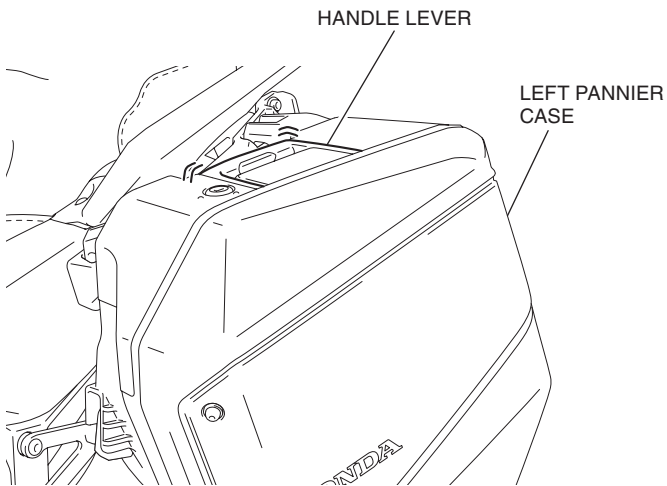

10. Check that the left pannier case is installed securely by swinging the left pannier case taking care not to fall the motorcycle down.
 - **The left pannier case can come off during riding unless it is mounted securely.**

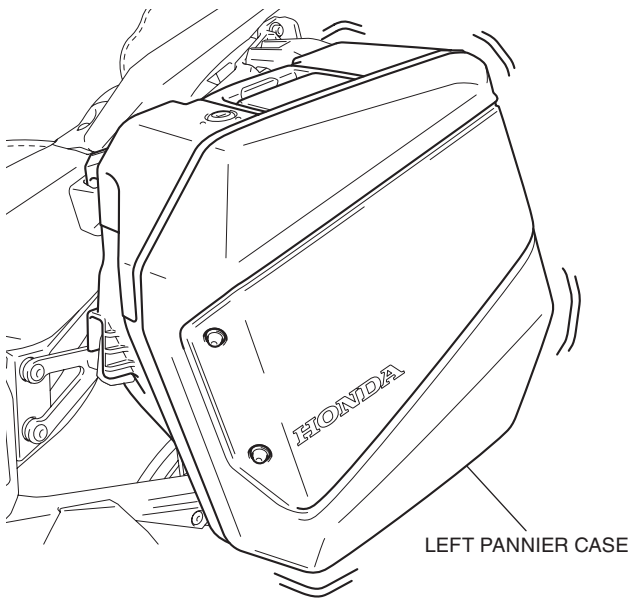

11. Install the right pannier case in the same manner as the left side.

How to Remove the Panniers

1. Insert the key and release the lock by turning the key clockwise.

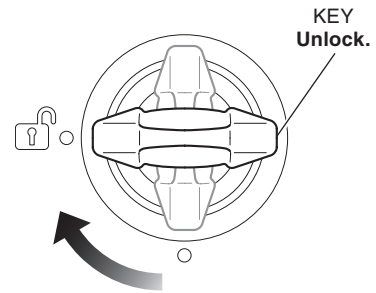

2. Raise the handle lever as shown.

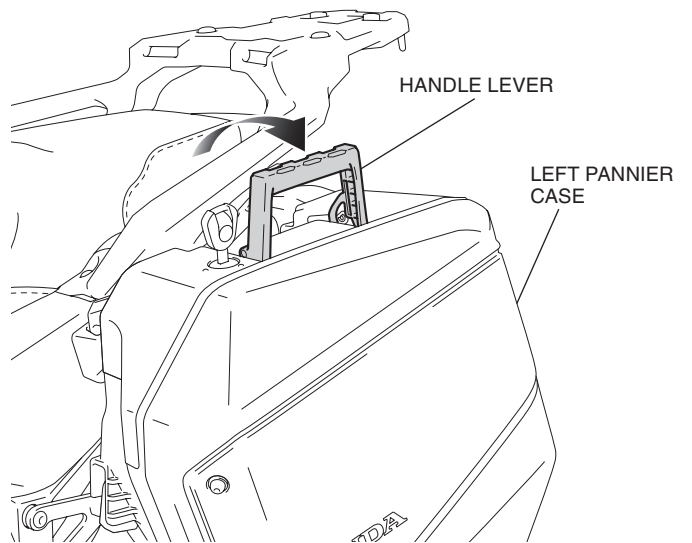

3. Remove the panniers in the reverse order of installation.

How to Store the Pannier Inner bag

1. Open the pannier case and store the pannier inner bag.
2. Close the pannier case.
 - **Be careful not to have the stored item pinched when the pannier case is closed.**