



INSTALLATION INSTRUCTIONS

Accessory

SIDE PIPE
P/N 08P70-MKH-D00

Application

ADV750

Publication No.

MII

Issue Date

September 2020

Honda Dealer: Please give a copy of these instructions to your customer.

PARTS LIST

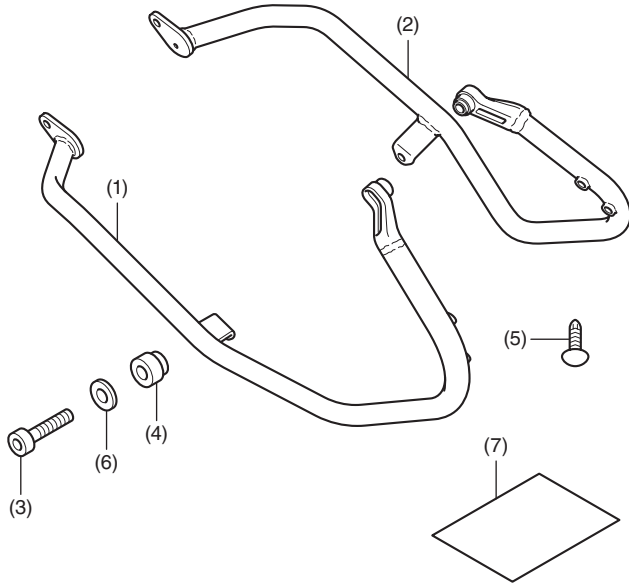

No.	Description	Qty
(1)	Right side pipe	1
(2)	Left side pipe	1
(3)	8 mm socket bolt	6
(4)	Collar	4
(5)	Clip	4
(6)	Washer	6
(7)	URL paper	1

TOOLS REQUIRED

Hex wrench (6 mm)

Torque wrench

TORQUE CHART

Tighten all screws, bolts, and nuts to their specified torque values. Refer to the Service Manual for the torque values of the removed parts.

Item	N·m	kgf·m	lbf·ft
8 mm socket bolt	22	2.2	16

INSTALLATION

▲ CAUTION

- To prevent burns, allow the engine, exhaust system, radiator, etc., to cool before installing the accessory.

1. Remove the bolts as shown.

- Repeat on the right side.

<Left side>

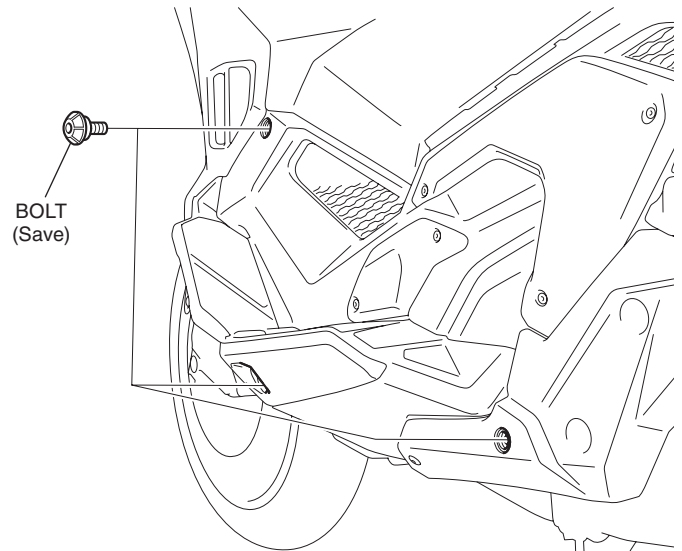

2. Install the clips as shown.

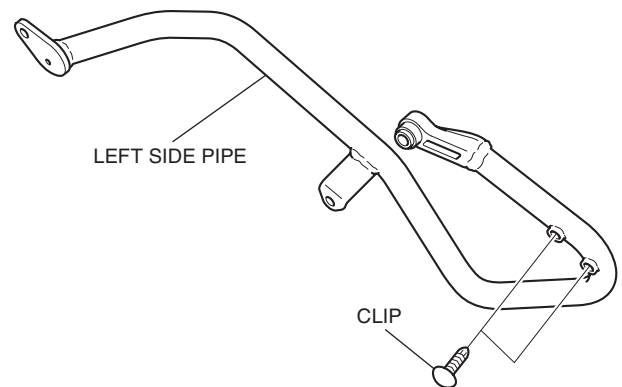

3. Loosely install the left side pipe as shown.
<Left side>

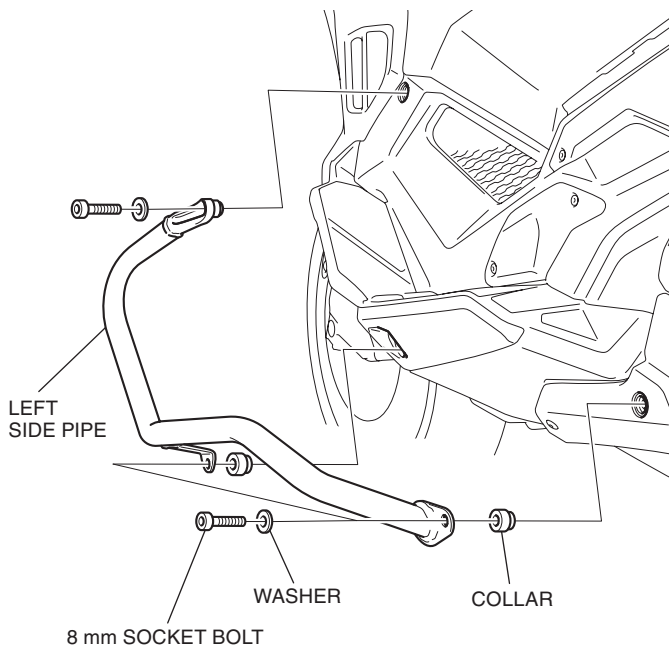

4. Securely tighten the 8 mm socket bolt as shown.
<Left side>

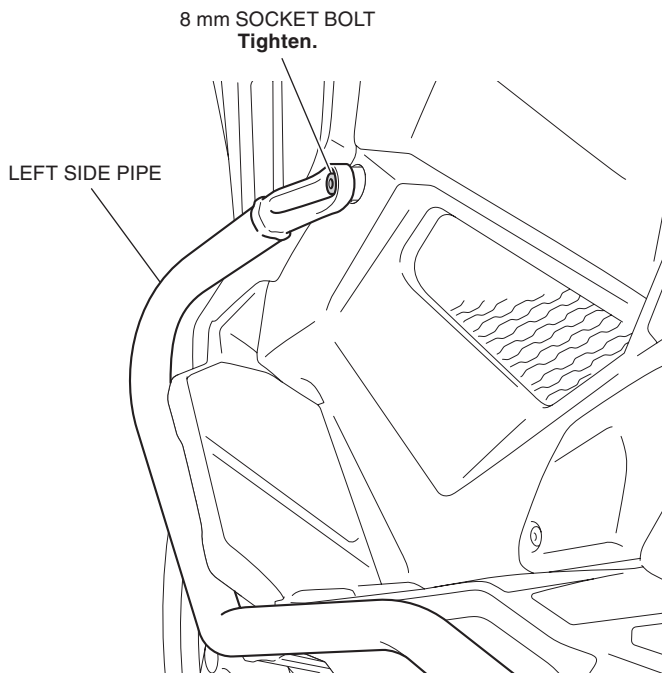

5. Tighten all the loosely installed parts securely.
6. Install the right side pipe in the same manner as the left side.

Please Convey the Following Information to the Customer During Delivery

- Do not attempt to move the motorcycle with holding side pipe and also to apply extra pressure in them.