



# INSTALLATION INSTRUCTIONS

Accessory

FOOT DEFLECTOR  
P/N 08R71-MKW-D00

Application

NC750XA

Publication No.

MII

Issue Date

January 2021

**Honda Dealer: Please give a copy of these instructions to your customer.**

## PARTS LIST

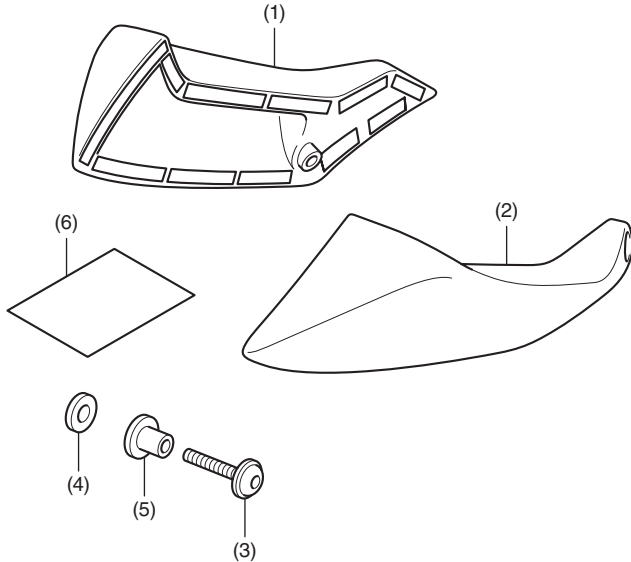

No.	Description	Qty
(1)	Right foot deflector	1
(2)	Left foot deflector	1
(3)	5 mm socket screw	2
(4)	Collar	2
(5)	Flange collar	2
(6)	URL paper	1

## TOOLS AND SUPPLIES REQUIRED

Hex wrench (3 mm)  
Isopropyl alcohol  
Shop towel  
Torque wrench

## TORQUE CHART

Tighten all screws, bolts, and nuts to their specified torque values. Refer to the Service Manual for the torque values of the removed parts.

Item	N·m	kgf·m	lbf·ft
5 mm socket screw	5.2	0.5	3.8

## INSTALLATION

### ▲ CAUTION

- To prevent burns, allow the engine, exhaust system, radiator, etc., to cool before installing the accessory.

### NOTE:

- Heat the bonding surfaces with a hair dryer if the ambient air temperature is below 70°F (21°C).
- The adhesive reaches full strength in 72 hours. Wait at least 24 hours before riding your motorcycle.

- Remove the screw as shown.

- Repeat on the left side.

<Right side>

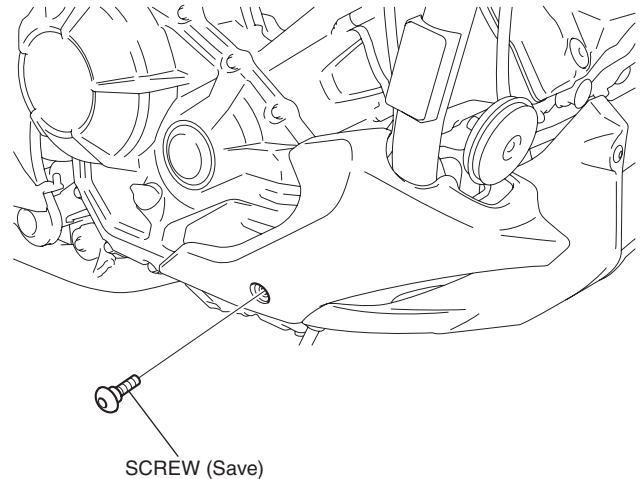

- Clean the surface of the area shown using an isopropyl alcohol.

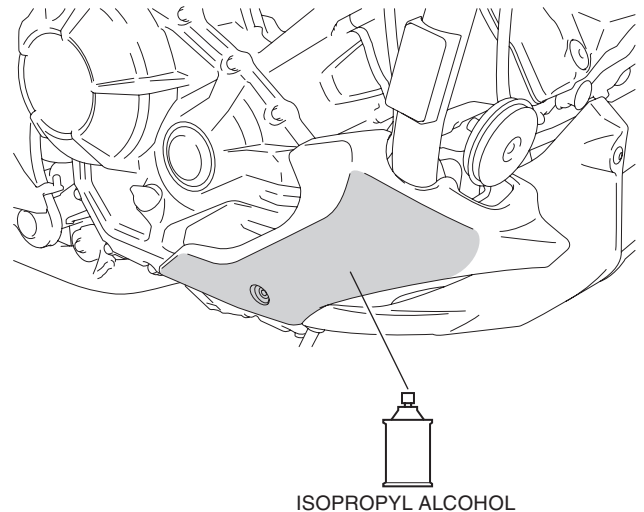

3. Peel off the adhesive backings on the right foot deflector as shown.

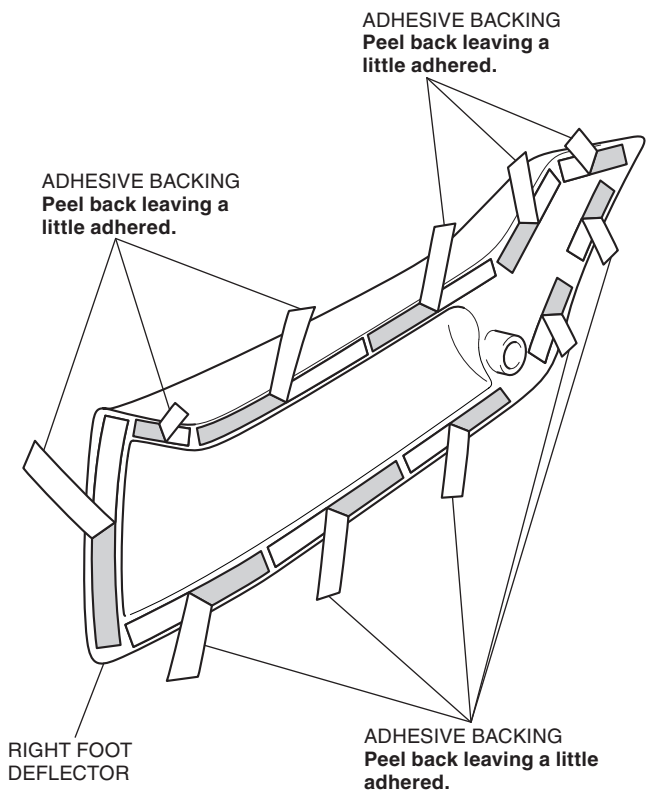

4. Attach the right foot deflector and loosely install the 5 mm socket screw as shown.

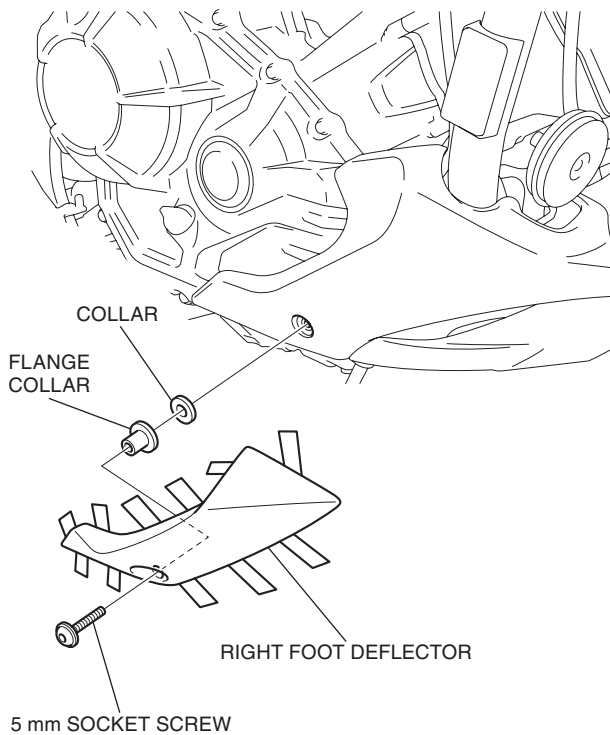

5. Remove the adhesive backings as shown.

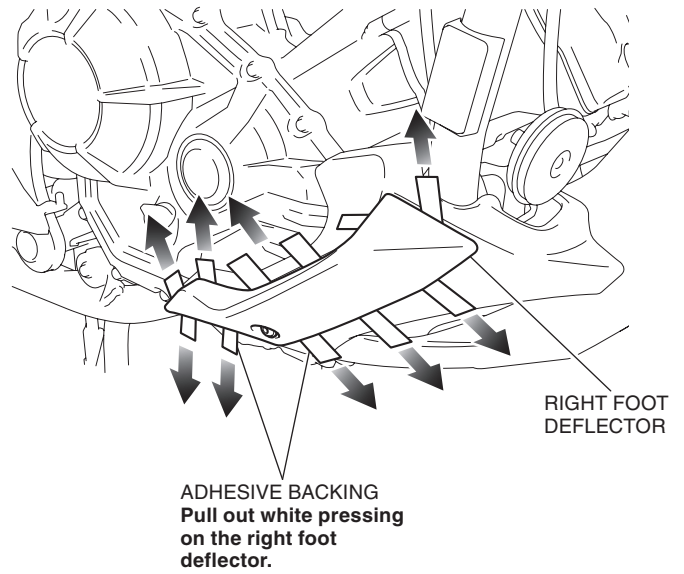

6. Apply adequate pressure to the attached right foot deflector.
7. Tighten the loosely installed parts securely.
8. Install the left foot deflector in the same manner as the right side.