



INSTALLATION INSTRUCTIONS

Accessory
**FRONT SIDE PIPE
P/N 08P71-MKW-D00**

Application
NC750XA/XD

Publication No.
MII
Issue Date
January 2021

Honda Dealer: Please give a copy of these instructions to your customer.

PARTS LIST

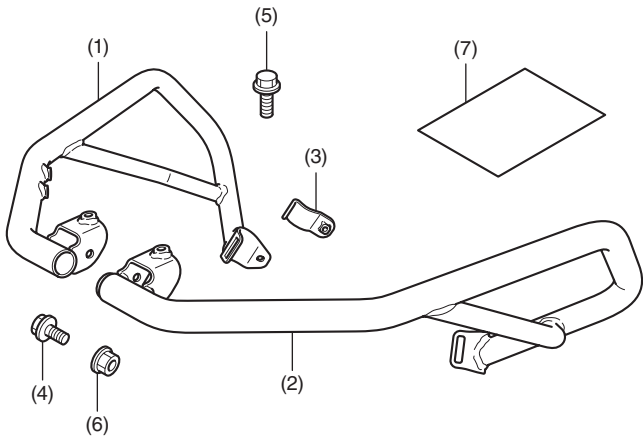

No.	Description	Qty
(1)	Right front side pipe	1
(2)	Left front side pipe	1
(3)	Front side pipe holder	2
(4)	6 mm flange bolt (short)	3
(5)	6 mm flange bolt (long)	2
(6)	6 mm flange nut	3
(7)	URL paper	1

TOOLS REQUIRED

- Socket (10 mm)
- Ratchet
- Box-end wrench (10 mm)
- Open-end wrench (10 mm)
- Torque wrench

TORQUE CHART

Tighten all screws, bolts, and nuts to their specified torque values. Refer to the Service Manual for the torque values of the removed parts.

Item	N·m	kgf·m	lbf·ft
6 mm flange bolt and nut	12	1.2	9

INSTALLATION

▲ CAUTION

- To prevent burns, allow the engine, exhaust system, radiator, etc., to cool before installing the accessory.

- Loosely install the left front side pipe and front side pipe holder as shown.

<Left side>

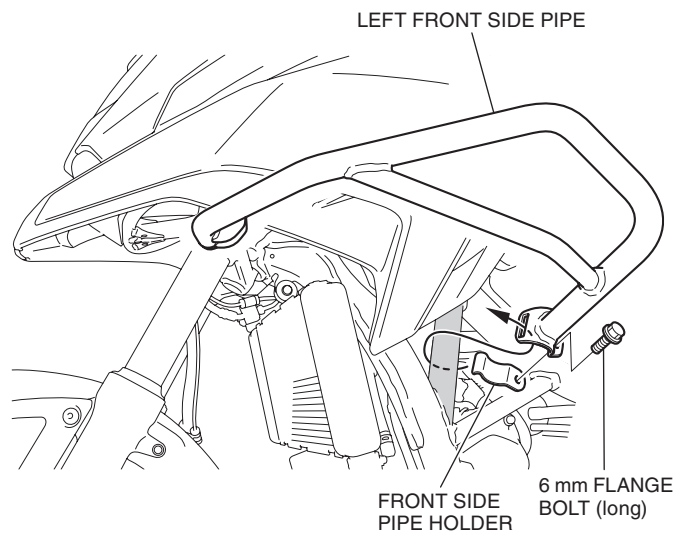

- Loosely install the left front side pipe as shown.

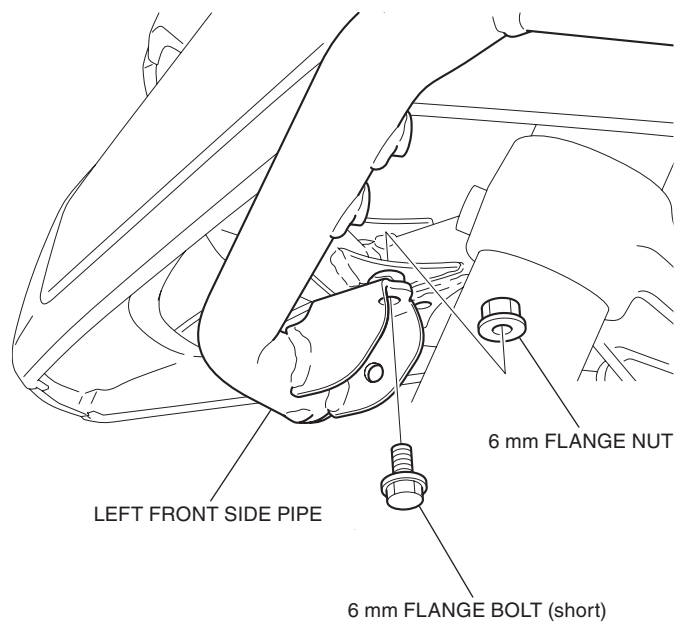

- Loosely install the right front side pipe and front side pipe holder in the same manner as the left side.
- Loosely install the right front side pipe as shown.

<Right side>

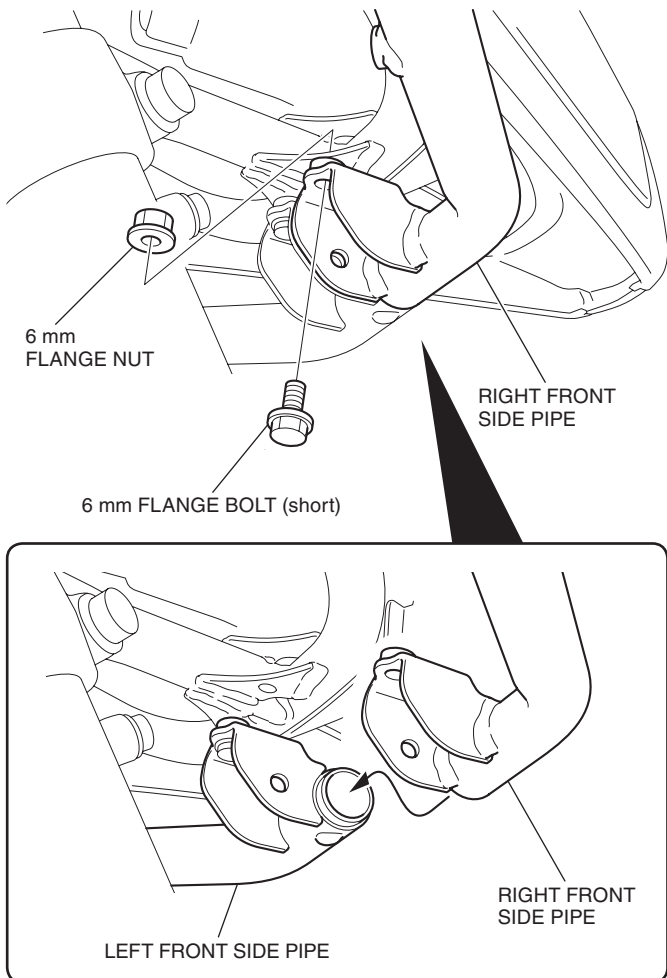

- Install the 6 mm flange bolt (short) and 6 mm flange nut as shown.

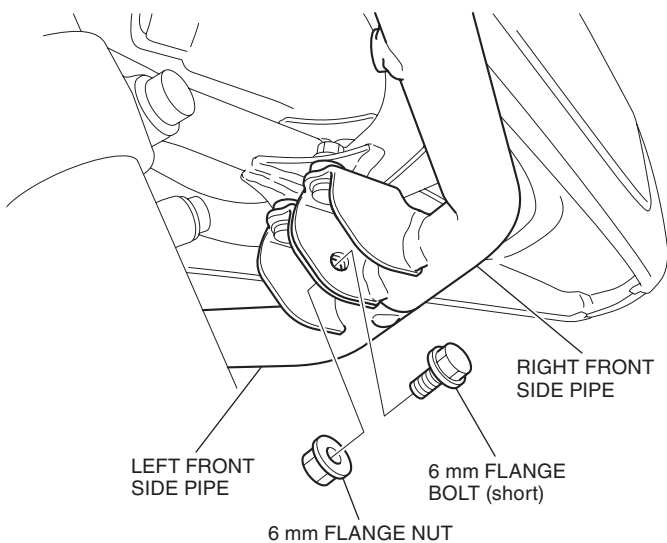

- Tighten all loosely installed hardware to the specifications in the torque chart.

Please Convey the Following Information to the Customer During Delivery

NOTICE:

- DO NOT GRASP THE FRONT SIDE PIPE OR ATTACHED ACCESSORIES TO MOVE THE MOTORCYCLE AS IT MAY DAMAGE THE MOTORCYCLE AND ACCESSORIES.**